

# Motor-protective circuit-breakers

Short down times of machines and systems require a fast re-availability of the system. With the PKZ, fuseless short-circuit protection and overload protection is provided in one device.



### Motor-protective circuit-breakers PKZM0 to 32 A and PKZM4 to 65 A

- Simple engineering as most have 50 kA short-circuit rating
- trip-indication enables remote diagnostics
- Higher safety by use as main-switch or repair and maintenance switch

Page 8/4



### Motor-protective circuit-breaker PKZM01 pushbutton operation of motor-protective circuit-breakers in enclosure

- IP40 and IP65 offer solutions for all environmental conditions
- Integrated Emergency-stop pushbutton reduces wiring

Pages 8/3 and 8/14

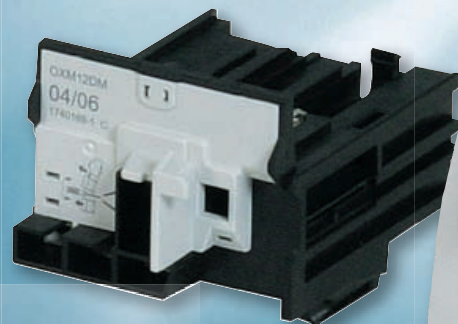

### Tool-less plug connection Plug-in wire jumpers for assembly of motor starters

- Plug-in wire jumpers save wiring time
- Short mounting times as only a top-hat rail is necessary
- Suitable design for high value systems

Page 8/2

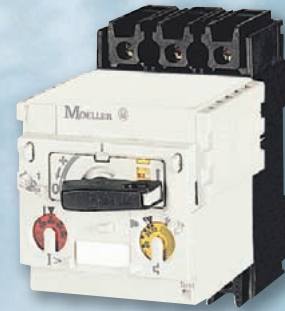

### Motor-protective circuit-breaker PKZ2

Motor protection and system protective switch up to 40 A

- Higher flexibility due to plug-in trip blocks
- Remote operator enables switching from central desk
- High power switch-block for heavy switching conditions
- ATEX approval for the protection of EEx e motors up to 40 A

Page 8/2



## Motor-protective circuit-breakers PKZM01, PKZM0, PKZM4



|   | Page |
|---|------|
| <b>System overview</b>  | 8/2  |
| <b>Ordering</b>   |      |
| Motor-protective circuit-breakers                               | 8/3  |
| Motor-protective circuit-breakers for starter combinations      | 8/6  |
| Transformer-protective circuit-breakers                         | 8/6  |
| Auxiliary contact   | 8/8  |
| Auxiliary contacts, voltage releases                            | 8/10 |
| <b>Engineering</b>  |      |
| Accessories for motor-protective circuit-breakers in enclosures | 8/12 |
| <b>Ordering</b>   |      |
| Insulated enclosure   | 8/14 |
| Accessories   | 8/17 |
| Busbar adapter  | 8/19 |
| Wiring sets   | 8/21 |
| Three-phase commoning links                                     | 8/22 |
| Actuating voltages  | 8/24 |
| <b>Engineering</b>  |      |
| Motor-protective circuit-breakers                               | 8/47 |
| Characteristic curves   | 8/48 |
| Switching capacity  | 8/49 |
| <b>Technical data</b>   |      |
| Motor-protective circuit-breakers                               | 8/54 |
| Auxiliary contact   | 8/56 |
| <b>Dimensions</b>   |      |
| Motor-protective circuit-breakers PKZM01, PKZM0                 | 8/62 |
| Accessories   | 8/62 |
| Motor-protective circuit-breakers PKZM4                         | 8/67 |
| Accessories   | 8/67 |

## Motor-protective circuit-breakers PKZ2



|  | Page |
|--|------|
| <b>System overview</b>                         | 8/25 |
| <b>Ordering</b>                                |      |
| Motor-protective circuit-breakers              | 8/26 |
| Circuit-breakers                               | 8/26 |
| Compact starter, high-capacity compact starter | 8/28 |
| Motor protection modules                       | 8/30 |
| Components for system protection               | 8/32 |
| Insulated enclosures                           | 8/33 |
| Auxiliary contacts                             | 8/34 |
| Current limiter                                | 8/35 |
| Voltage releases                               | 8/36 |
| Remote operators                               | 8/38 |
| Contact modules                                | 8/40 |
| Accessories for contact modules                | 8/42 |
| Accessories                                    | 8/44 |
| Actuating voltages                             | 8/45 |
| <b>Engineering</b>                             |      |
| Motor-protective circuit-breakers              | 8/47 |
| Characteristic curves                          | 8/51 |
| Switching capacity                             | 8/53 |
| <b>Technical data</b>                          |      |
| Motor-protective circuit-breakers              | 8/57 |
| (High-capacity) contact module                 | 8/58 |
| Current limiter                                | 8/58 |
| Auxiliary contacts                             | 8/59 |
| Voltage releases                               | 8/60 |
| Remote operators                               | 8/61 |
| <b>Dimensions</b>                              |      |
| Motor-protective circuit-breakers              | 8/69 |
| Accessories                                    | 8/69 |

Motor protection, transformer protection, conductor and cable protection

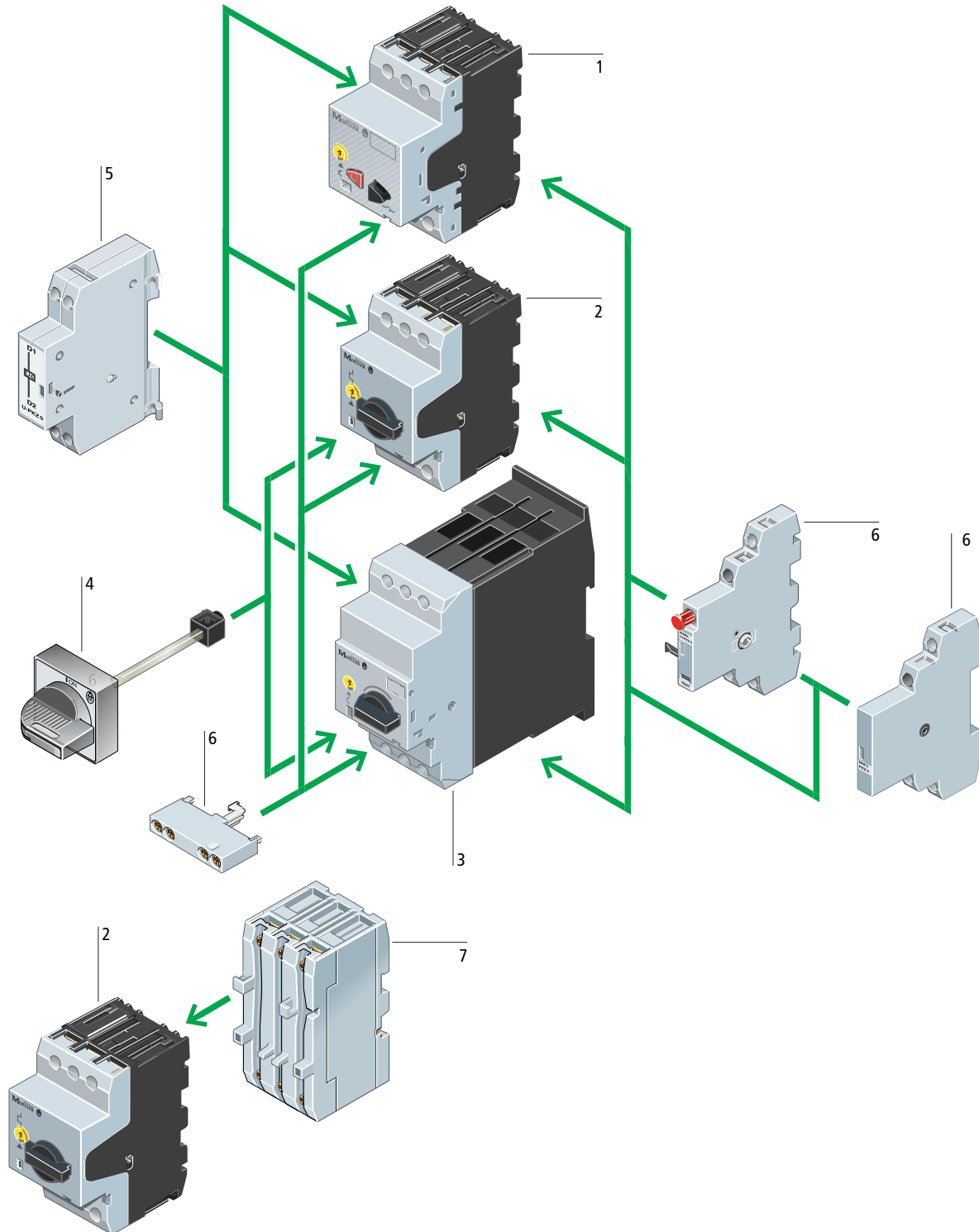

### Basic devices

PKZM01 motor-protective circuit-breakers 1

→ Page 8/3

PKZM0 motor-protective circuit-breakers 2

→ Page 8/4

PKZM4 motor-protective circuit-breakers 3

→ Page 8/4

### Add-on functions

Standard auxiliary contacts 6

→ Page 8/8

Voltage releases 5

→ Page 8/11

Current limiter 7

→ Page 8/11

### Mounting accessories

Door coupling rotary handle IP65 4

→ Page 8/17

Insulated enclosures

→ Page 8/14

Mounting/wiring

→ Page 8/19



Motor-protective circuit-breakers

| Max. motor rating |          |          | Rated uninterrupted current | Setting range        |                        | Screw terminals | Price see price list RG | Std. pack |
|-------------------|----------|----------|-----------------------------|----------------------|------------------------|-----------------|-------------------------|-----------|
| AC-3              |          |          |                             | Overload releases    | Short-circuit releases |                 |                         |           |
| 220 V             | 380 V    | 440 V    |                             |                      |                        |                 |                         |           |
| 230 V             | 400 V    |          |                             |                      |                        |                 |                         |           |
| 240 V             | 415 V    |          |                             |                      |                        |                 |                         |           |
| <i>P</i>          | <i>P</i> | <i>P</i> | <i>I<sub>u</sub></i>        | <i>I<sub>r</sub></i> | <i>I<sub>rm</sub></i>  |                 |                         |           |
| kW                | kW       | kW       | A                           | A                    | A                      |                 |                         |           |
|                   |          |          |                             |                      |                        |                 |                         |           |

Motor-protective circuit-breakers, Type "1" and Type "2" coordination

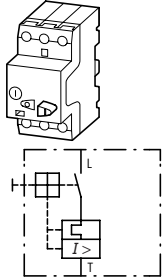

|      |      |      |      |             |     |                       |       |
|------|------|------|------|-------------|-----|-----------------------|-------|
| -    | -    | -    | 0.16 | 0.1...0.16  | 2.2 | PKZM01-0,16<br>278475 | 1 off |
| -    | 0.06 | 0.06 | 0.25 | 0.16...0.25 | 3.5 | PKZM01-0,25<br>278476 |       |
| 0.06 | 0.09 | 0.12 | 0.4  | 0.25...0.4  | 5.6 | PKZM01-0,4<br>278477  |       |
| 0.09 | 0.12 | 0.18 | 0.63 | 0.4...0.63  | 8.8 | PKZM01-0,63<br>278478 |       |
| 0.12 | 0.25 | 0.25 | 1    | 0.63...1    | 14  | PKZM01-1<br>278479    |       |
| 0.25 | 0.55 | 0.55 | 1.6  | 1...1.6     | 22  | PKZM01-1,6<br>278480  |       |
| 0.37 | 0.75 | 1.1  | 2.5  | 1.6...2.5   | 35  | PKZM01-2,5<br>278481  |       |
| 0.75 | 1.5  | 1.5  | 4    | 2.5...4     | 56  | PKZM01-4<br>278482    |       |
| 1.1  | 2.2  | 3    | 6.3  | 4...6.3     | 88  | PKZM01-6,3<br>278483  |       |
| 2.2  | 4    | 4    | 10   | 6.3...10    | 140 | PKZM01-10<br>278484   |       |
| 3    | 5.5  | 5.5  | 12   | 8...12      | 168 | PKZM01-12<br>278485   |       |
| 4    | 7.5  | 9    | 16   | 10...16     | 224 | PKZM01-16<br>283390   |       |

Notes

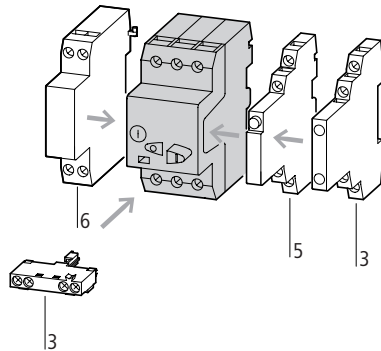

Accessories

- 3 Standard auxiliary contact
- 5 Trip-indicating auxiliary contact
- 6 Shunt release, undervoltage release

Page

- 8/8
- 8/11
- 8/11

Single-phasing sensitivity according to IEC/EN 60947-4-1, VDE 0660 Part 102.  
Can be snap-fitted to IEC/EN 60715 top-hat rail with 7.5 or 15 mm height





PKZM0, PKZM4

Moeller HPL0211-2007/2008

http://catalog.moeller.net

| Max. motor rating |       |       |       |       | Rated<br>uninterrupted<br>current | Overload<br>releases | Short-circuit<br>releases |
|-------------------|-------|-------|-------|-------|-----------------------------------|----------------------|---------------------------|
| AC-3              |       |       |       |       |                                   |                      |                           |
| 220 V             | 380 V | 440 V | 500 V | 660 V | $I_u$                             | $r$                  | $m$                       |
| 230 V             | 400 V |       |       | 690 V |                                   |                      |                           |
| 240 V             | 415 V |       |       |       |                                   |                      |                           |
| $P$               | $P$   | $P$   | $P$   | $P$   | $I_u$                             | $r$                  | $m$                       |
| kW                | kW    | kW    | kW    | kW    | A                                 | A                    | A                         |

| Screw terminals         |                | Std. pack |
|-------------------------|----------------|-----------|
| Part no.<br>Article no. | see price list |           |

Motor-protective circuit-breakers, Type "1" and Type "2" coordination

|  |      |      |      | 0.06 | 0.16 | 0.1...0.16 | 2.2        | PKZM0-0,16 |                     | off |  |
|--|------|------|------|------|------|------------|------------|------------|---------------------|-----|--|
|  |      |      |      |      |      |            |            | PKZM0-0,25 |                     |     |  |
|  | 0.06 | 0.09 | 0.12 | 0.12 | 0.18 | 0.4        | 0.25...0.4 | 5.6        | PKZM0-0,4<br>072732 |     |  |
|  | 0.09 | 0.12 | 0.18 | 0.25 | 0.25 | 0.63       | 0.4...0.63 | 8.8        | PKZM0-0,63          |     |  |
|  |      |      |      |      |      |            |            |            | PKZM0-1             |     |  |
|  |      |      |      |      |      |            |            |            | PKZM0-1,6           |     |  |
|  |      |      |      |      |      |            |            |            | PKZM0-2,5           |     |  |
|  |      |      |      |      |      |            |            |            | PKZM0-4             |     |  |
|  |      |      |      |      |      |            |            |            | PKZM0-6,3           |     |  |
|  |      |      |      |      |      |            |            |            | PKZM0-10            |     |  |
|  |      |      |      |      |      |            |            |            | PKZM0-12            |     |  |
|  |      |      |      |      |      |            |            |            | PKZM0-16            |     |  |
|  |      |      |      |      |      |            |            |            | PKZM0-20            |     |  |
|  |      |      |      |      |      |            |            |            | PKZM0-25            |     |  |
|  |      |      |      |      |      |            |            |            | PKZM0-32            |     |  |

Motor-protective circuit-breakers, Type "1" and Type "2" coordination

|  |  |  |  |  |  |  |  |  |          |  |  |
|--|--|--|--|--|--|--|--|--|----------|--|--|
|  |  |  |  |  |  |  |  |  | PKZM4-16 |  |  |
|  |  |  |  |  |  |  |  |  | PKZM4-25 |  |  |
|  |  |  |  |  |  |  |  |  | PKZM4-32 |  |  |
|  |  |  |  |  |  |  |  |  | PKZM4-40 |  |  |
|  |  |  |  |  |  |  |  |  | PKZM4-50 |  |  |
|  |  |  |  |  |  |  |  |  | PKZM4-58 |  |  |
|  |  |  |  |  |  |  |  |  | PKZM4-63 |  |  |

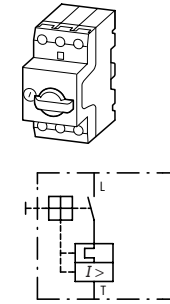

http://catalog.moeller.net



| Incoming side screw terminals<br>outgoer side springloaded terminals |                | Spring-loaded terminals |                | Std. pack | Notes |
|--|----------------|-------------------------|----------------|-----------|-------|
| Article no.  | see price list | Article no.             | see price list |           |       |

|                        |  |                       |  |  |  |
|------------------------|--|-----------------------|--|--|--|
| PKZM0-0,16-SC          |  | PKZM0-0,16-C          |  |  |  |
| 229829                 |  | 229670                |  |  |  |
| PKZM0-0,4-SC<br>229830 |  | PKZM0-0,4-C<br>229671 |  |  |  |
| PKZM0-0,63-SC          |  | PKZM0-0,63-C          |  |  |  |
| PKZM0-1-SC             |  | PKZM0-1-C             |  |  |  |
| PKZM0-1,6-SC           |  | PKZM0-1,6-C           |  |  |  |
| PKZM0-2,5-SC           |  | PKZM0-2,5-C           |  |  |  |
| PKZM0-4-SC             |  | PKZM0-4-C             |  |  |  |
| PKZM0-6,3-SC           |  | PKZM0-6,3-C           |  |  |  |
| PKZM0-10-SC            |  | PKZM0-10-C            |  |  |  |
| PKZM0-12-SC            |  | PKZM0-12-C            |  |  |  |
| PKZM0-16-SC            |  | PKZM0-16-C            |  |  |  |

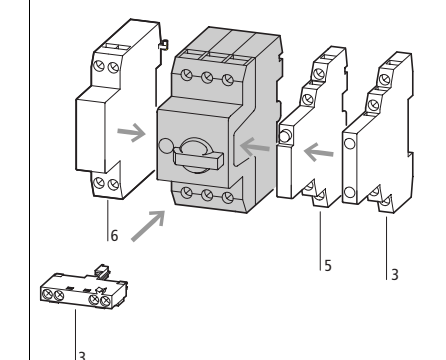

**Accessories**

- 3 Standard auxiliary contact → 8/11
- 5 Trip-indicating auxiliary contact → 8/11
- 6 Shunt release, undervoltage release 8/11

Single-phasing sensitivity to IEC/EN 60947-4-1  
Can be snap-fitted to IEC/EN 60715 top-hat rail with 7.5 or 15 mm height  
⊕ PTB 02 ATEX 3151, see manual 8/18

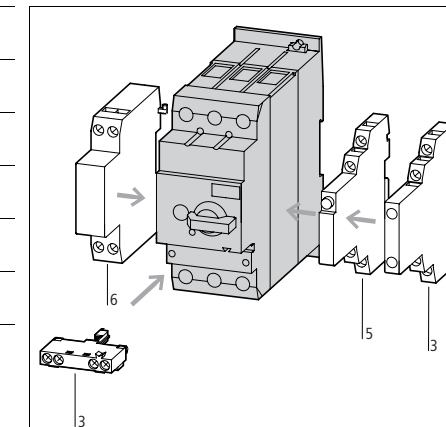

Motor-protective circuit-breakers











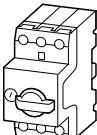
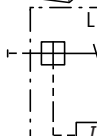
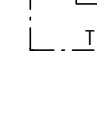

Motor-protective circuit-breakers



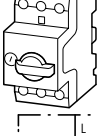
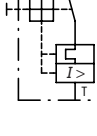



| Max. motor rating<br>AC-3 |       |       |       |       | Rated<br>uninterrupted | Overload<br>releases | Short-circuit<br>releases | Article no. | see price list | Std. pack |
|---------------------------|-------|-------|-------|-------|------------------------|----------------------|---------------------------|-------------|----------------|-----------|
| 220 V                     | 380 V | 440 V | 500 V | 660 V |                        |                      |                           |             |                |           |
| 230 V                     | 400 V |       |       | 690 V |                        |                      |                           |             |                |           |
| 240 V                     | 415 V |       |       |       |                        |                      |                           |             |                |           |
| kW                        | kW    | kW    | kW    | kW    | A                      | A                    | A                         |             |                |           |

**Motor-protective circuit-breakers for starter combinations**

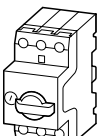
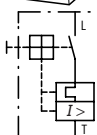
Short-circuit protective circuit-breaker without overload function

|   |      |      |      |      |      |      |     |     |                            |       |
|---|------|------|------|------|------|------|-----|-----|----------------------------|-------|
|    | -    | -    | -    | -    | 0.06 | 0.16 | --- | 2.2 | <b>PKM0-0,16</b><br>072720 | 1 off |
|    | -    | 0.06 | 0.06 | 0.06 | 0.12 | 0.25 | --- | 3.5 | <b>PKM0-0,25</b><br>072721 |       |
|    | 0.06 | 0.09 | 0.12 | 0.12 | 0.18 | 0.4  | --- | 5.6 | <b>PKM0-0,4</b><br>072722  |       |
|   | 0.09 | 0.12 | 0.18 | 0.25 | 0.25 | 0.63 | --- | 8.8 | <b>PKM0-0,63</b><br>072723 |       |
|  | 0.12 | 0.25 | 0.25 | 0.38 | 0.55 | 1    | --- | 14  | <b>PKM0-1</b><br>072724    |       |
|  | 0.25 | 0.37 | 0.55 | 0.75 | 1.1  | 1.6  | --- | 22  | <b>PKM0-1,6</b><br>072725  |       |
|  | 0.37 | 0.75 | 1.1  | 1.1  | 1.5  | 2.5  | --- | 35  | <b>PKM0-2,5</b><br>072726  |       |
|  | 0.75 | 1.5  | 1.5  | 2.2  | 3    | 4    | --- | 56  | <b>PKM0-4</b><br>072727    |       |
|  | 1.1  | 2.2  | 3    | 3    | 4    | 6.3  | --- | 88  | <b>PKM0-6,3</b><br>072728  |       |
|  | 2.2  | 4    | 4    | 4    | 7.5  | 10   | --- | 140 | <b>PKM0-10</b><br>072729   |       |
|  | 3    | 5.5  | 5.5  | 5.5  | 11   | 12   | --- | 168 | <b>PKM0-12</b><br>278490   |       |
|  | 4    | 7.5  | 9    | 9    | 12.5 | 16   | --- | 224 | <b>PKM0-16</b><br>044502   |       |
|  | 5.5  | 9    | 11   | 12.5 | 15   | 20   | --- | 280 | <b>PKM0-20</b><br>203594   |       |
|  | 5.5  | 12.5 | 12.5 | 15   | 22   | 25   | --- | 350 | <b>PKM0-25</b><br>044503   |       |
|  | 7.5  | 15   | 15   | 22   | 30   | 32   | --- | 448 | <b>PKM0-32</b><br>278491   |       |

**Transformer-protective circuit-breakers**

|   |   |   |   |   |      |             |      |                               |       |
|---|---|---|---|---|------|-------------|------|-------------------------------|-------|
|  | - | - | - | - | 0.16 | 0.1...0.16  | 2.4  | <b>PKZM0-0,16-T</b><br>088907 | 1 off |
|  | - | - | - | - | 0.25 | 0.16...0.25 | 4.25 | <b>PKZM0-0,25-T</b><br>088908 |       |
|  | - | - | - | - | 0.4  | 0.25...0.4  | 6.8  | <b>PKZM0-0,4-T</b><br>088909  |       |
|  | - | - | - | - | 0.63 | 0.4...0.63  | 12   | <b>PKZM0-0,63-T</b><br>088910 |       |
|  | - | - | - | - | 1    | 0.63...1    | 20   | <b>PKZM0-1-T</b><br>088911    |       |
|  | - | - | - | - | 1.6  | 1...1.6     | 32   | <b>PKZM0-1,6-T</b><br>088912  |       |
|  | - | - | - | - | 2.5  | 1.6...2.5   | 50   | <b>PKZM0-2,5-T</b><br>088913  |       |
|  | - | - | - | - | 4    | 2.5...4     | 84   | <b>PKZM0-4-T</b><br>088914    |       |
|  | - | - | - | - | 6.3  | 4...6.3     | 141  | <b>PKZM0-6,3-T</b><br>088915  |       |
|  | - | - | - | - | 10   | 6.3...10    | 224  | <b>PKZM0-10-T</b><br>088916   |       |
|  | - | - | - | - | 12   | 8...12      | 224  | <b>PKZM0-12-T</b><br>278492   |       |
|  | - | - | - | - | 16   | 10...16     | 358  | <b>PKZM0-16-T</b><br>088917   |       |
|  | - | - | - | - | 20   | 16...20     | 380  | <b>PKZM0-20-T</b><br>088918   |       |
|  | - | - | - | - | 25   | 20...25     | 420  | <b>PKZM0-25-T</b><br>278493   |       |



Motor-protective circuit-breakers

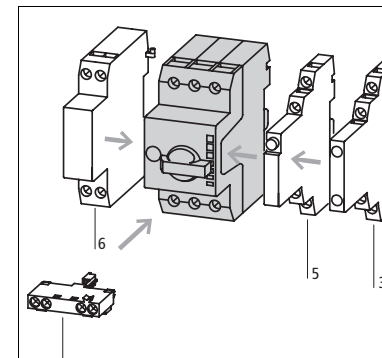

When using the PKM0 as short-circuit protection for motors with heavy starting duty, the rated operational current  $I_e$  must be over-dimensioned during engineering with the following factors:

- CLASS 5 = 1.0
- CLASS 10 = 1.0
- CLASS 15 = 1.22
- CLASS 20 = 1.41
- CLASS 25 = 1.58
- CLASS 30 = 1.73
- CLASS 35 = 1.89
- CLASS 40 = 2.0

- 3 Standard auxiliary contact 8/8
- 5 Trip-indicating auxiliary contact 8/11
- 6 Shunt release, undervoltage release 8/11
- Additional accessories 13/35

Can be snap-fitted to IEC/EN 60715 top-hat rail with 7.5 or 15 mm height.  
Assignment of the short-circuit protective breakers and contactors in "Fuseless motor-starter combinations" section.  
An appropriate overload relay must be fitted to protect motors against overload.

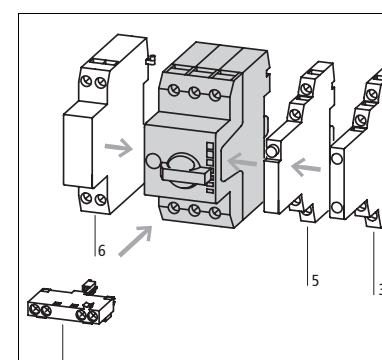

- 3 Standard auxiliary contact 8/8
- 5 Trip-indicating auxiliary contact 8/11
- 6 Shunt release, undervoltage release 8/11

For the protection of transformers with a high inrush current  
Can be snap-fitted to IEC/EN 60715 top-hat rail with 7.5 or 15 mm height  
Single-phasing sensitivity to IEC/EN 60947-4-1

| Contacts                                     | Contact diagram | Contact sequence | For use with            | Order number for separate orders            | see price list       | Std. pack |
|--|-----------------|------------------|-------------------------|---|----------------------|-----------|
| <b>Standard auxiliary contacts</b>           |                 |                  |                         |   |                      |           |
| <b>For motor-protective circuit-breakers</b> |                 |                  |                         |   |                      |           |
| 1 N/O 1 N/C                                  |                 |                  | Screw terminals         | PKZM01<br>PKZM0<br>PKZM4<br>PKZM0-T<br>PKM0 | <b>NHI11-PKZ0</b>    |           |
| 1 N/O 1 N/C                                  |                 |                  | Spring-loaded terminals |   | 229680               |           |
| 1 N/O 2 N/C                                  |                 |                  | Screw terminals         |   | 072895               |           |
| 2 N/O 1 N/C                                  |                 |                  |                         |   | 072894               |           |
| 1 N/O 1 N/C                                  |                 |                  |                         |   | <b>NHI-E-11-PKZ0</b> |           |
| 1 N/O  |                 |                  |                         |   | 082884               |           |
| 1 N/O  |                 |                  | Spring-loaded terminals |   | 229681               |           |
| 1 N/C  |                 |                  | Spring-loaded terminals |   | 229682               |           |

AGM, NHI-E-... trip-indicating auxiliary contact

The 45 mm (PKZM0) or 55 mm (PKZM4) widths of the motor-protective circuit-breakers remain unchanged.

|                                     |      |
|-------------------------------------|------|
| 1 Motor-protective circuit-breakers | 8/4  |
| 5 Trip-indicating auxiliary contact | 8/11 |
| Additional accessories              | 8/17 |

Motor-protective circuit-breakers

Motor-protective circuit-breakers

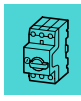
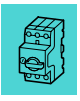

| Contacts   | Contact diagram | Contact sequence | For use with                                |
|--|-----------------|------------------|---|
| <p>N/O = Normally open<br/>N/C = Normally closed</p>   |                 |                  |   |
| <b>Trip-indicating auxiliary contacts</b>  |                 |                  |   |
| For motor-protective circuit-breakers  |                 |                  |   |
| <p>2 × 1 N/O</p>   |                 |                  | PKZM0<br>PKZM4<br>PKZM0-T<br>PKM0<br>PKZM01 |
| <p>2 × 1 N/C</p>   |                 |                  | PKZM0<br>PKZM4<br>PKZM0-T<br>PKM0<br>PKZM01 |
| <b>Early-make auxiliary contact</b>  |                 |                  |   |
| For motor-protective circuit-breakers  |                 |                  |   |
| <p>2 N/O</p>   |                 |                  | PKZM0<br>PKZM0-T<br>PKM0<br><br>PKZM01      |
| <b>Shunt releases</b>  |                 |                  |   |
| <p>Screw terminals</p>   |                 |                  | PKZM0<br>PKZM4<br>PKZM0-T<br>PKM0<br>PKZM01 |
| <b>Undervoltage releases</b>   |                 |                  |   |
| <p>Screw terminals</p>   |                 |                  | PKZM0<br>PKZM4<br>PKZM0-T<br>PKM0<br>PKZM01 |
| <p>Spring-loaded terminals</p>   |                 |                  |   |
| <b>Current limiters</b>  |                 |                  |   |
| To enhance the switching capacity of non-inherently safe motor-protective circuit-breakers PKZM0-16, -20, -25, -32 to 150 kA/440 V |                 |                  |   |
|  |                 |                  | PKZM0<br>PKZM4                              |

| Part no.<br>Order number for separate orders | Price<br>see price list | Std. pack | Notes  |
|--|-------------------------|-----------|--|
| AGM2-10-PKZ0<br>072898                       |                         | 2 off     | Can be fitted to the right of motor-protective circuit-breakers:<br><br>Can be combined with:<br>Standard auxiliary contact<br>NHI11-PKZ0<br>NHI12-PKZ0<br>NHI21-PKZ0<br>NHI-E-...   |
| AGM2-01-PKZ0<br>072899                       |                         | 2 off     | Differential indication:<br>a) General trip indication (overload)<br>b) Short-circuit trip<br><br>Local short-circuit indication by red indicator, manually resettable.  |
| VHI20-PKZ0<br>203595                         |                         | 2 off     | Can be fitted to front on motor-protective circuit-breaker, 45 mm width of the motor-protective circuit-breaker remains unchanged.   |
| VHI20-PKZ01<br>278495                        |                         | 5 off     | For early energization of undervoltage release, e.g. in emergency-stop circuits to EN 60204.   |
| A-PKZ0(230V50HZ)<br>073187                   |                         | 2 off     | Can be fitted to the left of:<br>Motor-protective circuit-breakers<br>Cannot be combined with:<br>U-PKZ0 undervoltage release<br>DC: Intermittent operation 5 s  |
| A-PKZ0(24VDC)<br>073200                      |                         | 2 off     |  |
| U-PKZ0(230V50HZ)<br>073135                   |                         | 2 off     | Can be fitted to the left of:<br>Motor-protective circuit-breakers<br>Cannot be combined with:<br>A-PKZ0 shunt release   |
| U-PKZ0-C(230V50HZ)<br>229683                 |                         | 2 off     | When combined with circuit-breaker, can be used as emergency-stop device to IEC/EN 60204.  |
| CL-PKZ0<br>082881                            |                         | 1 off     | Max. rated operational voltage $U_e = 690$ V, rated uninterrupted current $I_n = 63$ A<br>Can be used for individual and group protection<br>For group protection and in combination with PKZM4, order additional BK25/3 incoming terminal if required.<br>Mounting next to or behind the motor-protective circuit-breaker.<br>PKZM4: 16 – 63 A: 100 kA/400 V<br>PKZM4: 16 – 63 A: 10 kA/690 V |

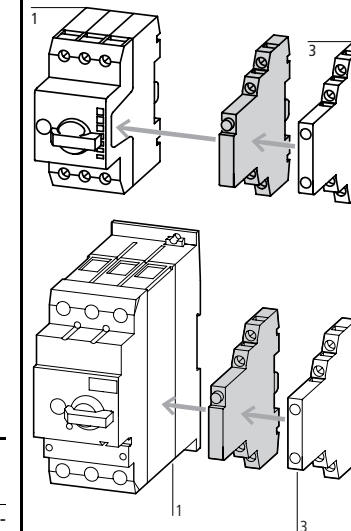

**Accessories**  
1 Motor-protective circuit-breaker  
3 Standard auxiliary contact



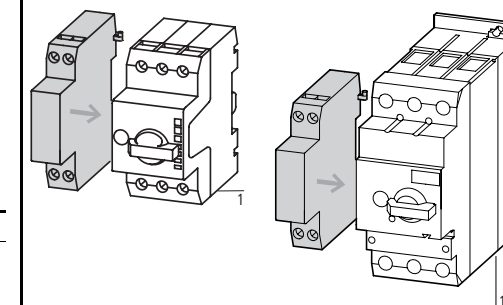







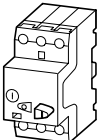

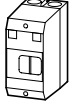
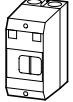
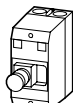
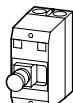
**Page**  
→ 8/4  
→ 8/8

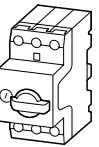

**Accessories**  
1 Interruptor protector de motor  
Further actuating voltages

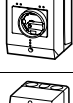
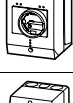
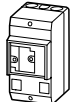
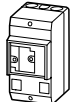
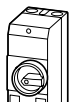
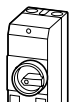
**Page**  
→ 8/4  
→ 8/24

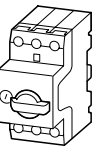

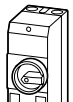
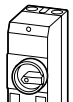
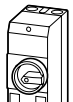
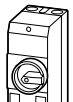
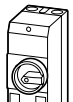
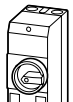
| Enclosures  |   | Accessories                    |               |             |              |               |             |              |                  |        |   |
|---|---|--------------------------------|---------------|-------------|--------------|---------------|-------------|--------------|------------------|--------|---|
| Part no.  | Part no.  | Degree of protect              | Handle colour | NHI...-PKZ0 | AGM2...-PKZ0 | NHI-E...-PKZ0 | VHI...-PKZ0 | VHI...-PKZ01 | U-PKZ0 or A-PKZ0 | L-PKZ0 |   |
| <b>Surface mounting enclosures</b>  |   |                                |               |             |              |               |             |              |                  |        |   |
| <b>Motor-protective circuit-breaker PKZM01</b>  |   |                                |               |             |              |               |             |              |                  |        |   |
|      |    | CI-PKZ01                       | IP40          | -           | -            | -             | ●           | -            | -                | ●      | ● |
|   |   |                                |               |             | -            | -             | -           | -            | ●                | ●      | ● |
|      |    | CI-PKZ01-G                     | IP65          | -           | -            | -             | ●           | -            | -                | ●      | ● |
|   |   |                                |               |             | -            | -             | -           | -            | ●                | ●      | ● |
|   |   |                                |               |             | ●            | -             | ●           | -            | ●                | -      | ● |
|      |    | CI-PKZ01-PVT<br>CI-PKZ01-PVS   | IP65          | Red-yellow  | -            | -             | ●           | -            | -                | ●      | ● |
|   |   |                                |               |             | -            | -             | -           | -            | ●                | ●      | ● |
|      |    | CI-PKZ01-SVB<br>CI-PKZ01-SVB-V | IP65          | -           | -            | -             | ●           | -            | -                | ●      | ● |
|   |   |                                |               |             | -            | -             | -           | -            | ● <sup>1)</sup>  | ●      | ● |
| <b>Motor-protective circuit-breaker PKZM0</b>   |   |                                |               |             |              |               |             |              |                  |        |   |
|    |  | CI-K2-PKZ0                     | IP41          | -           | ●            | -             | ●           | -            | -                | ●      | ● |
|   |   |                                |               |             | -            | ●             | ●           | -            | -                | ●      | ● |
|    |  | CI-K2-PKZ0-G                   | IP65          | Black       | ●            | -             | ●           | -            | -                | ●      | ● |
|   |   |                                |               |             | -            | ●             | ●           | -            | -                | ●      | ● |
|    |  | CI-K2-PKZ0-GR                  | IP65          | Red-yellow  | ●            | -             | ●           | -            | -                | ●      | ● |
|   |   |                                |               |             | -            | ●             | ●           | -            | -                | ●      | ● |
|    |  | CI-PKZ0-M                      | IP40          | -           | ●            | -             | ●           | -            | -                | ●      | ● |
|   |   |                                |               |             | -            | -             | ●           | -            | -                | ●      | ● |
|    |  | CI-PKZ0-GM                     | IP55          | Black       | ●            | -             | ●           | -            | -                | -      | ● |
|   |   |                                |               |             | -            | -             | ●           | -            | -                | ●      | ● |
|    |  | CI-PKZ0-GRM                    | IP55          | Red-yellow  | ●            | -             | ●           | -            | -                | -      | ● |
|   |   |                                |               |             | -            | -             | ●           | -            | -                | ●      | ● |
| <b>Motor-protective circuit-breaker PKZM0 + early-make auxiliary contact VHI-PKZ0</b> |   |                                |               |             |              |               |             |              |                  |        |   |
|    |  | CI-K2-PKZ0-GV                  | IP65          | Black       | ●            | -             | -           | ●            | -                | ●      | ● |
|   |   |                                |               |             | -            | ●             | -           | ●            | -                | ●      | ● |
|    |  | CI-K2-PKZ0-GRV                 | IP65          | Red-yellow  | ●            | -             | -           | ●            | -                | ●      | ● |
|   |   |                                |               |             | -            | ●             | -           | ●            | -                | ●      | ● |
|    |  | CI-K2-PKZ0-GVM                 | IP55          | Black       | ●            | -             | -           | ●            | -                | -      | ● |
|   |   |                                |               |             | -            | -             | -           | ●            | -                | ●      | ● |
|    |  | CI-K2-PKZ0-GRVM                | IP55          | Red-yellow  | ●            | -             | -           | ●            | -                | -      | ● |
|   |   |                                |               |             | -            | -             | -           | ●            | -                | ●      | ● |

**Notes**

The combination possibilities of circuit-breakers in an enclosure with accessory modules are identified by a ●  
<sup>1)</sup> always necessary



Accessories for motor-protective circuit-breaker in enclosures

http://catalog.moeller.net

Moeller HPL0211-2007/2008

PKZM4, PKZM01, PKZM0









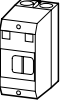

| Enclosures                                     |                            |                   |               | Accessories |              |               |             |                 |                  |        |
|--|----------------------------|-------------------|---------------|-------------|--------------|---------------|-------------|-----------------|------------------|--------|
| Part no.                                       | Part no.                   | Degree of protect | Handle colour | NHI...-PKZ0 | AGM2...-PKZ0 | NHI-E...-PKZ0 | VHI...-PKZ0 | VHI...-PKZ01    | U-PKZ0 or A-PKZ0 | L-PKZ0 |
| <b>Surface mounting enclosures</b>             |                            |                   |               |             |              |               |             |                 |                  |        |
| <b>Motor-protective circuit-breaker PKZM4</b>  |                            |                   |               |             |              |               |             |                 |                  |        |
|  | CI-K4-PKZ4-G               | IP65              | Black         | ●           | ●            | ●             | -           | -               | ●                | ●      |
|  | CI-K4-PKZ4-GR              | IP65              | Red-yellow    | ●           | ●            | ●             | -           | -               | ●                | ●      |
|  |                            |                   |               | ●           | ●            | -             | ●           | -               | ●                | ●      |
|  |                            |                   |               | ●           | ●            | -             | ●           | -               | ●                | ●      |
| <b>Installation enclosure</b>                  |                            |                   |               |             |              |               |             |                 |                  |        |
| <b>motor-protective circuit-breaker PKZM01</b> |                            |                   |               |             |              |               |             |                 |                  |        |
|  | E-PKZ01                    | IP40              | -             | -           | -            | ●             | -           | -               | ●                | ●      |
|  |                            |                   |               | ●           | -            | ●             | -           | ●               | ●                | ●      |
|  | E-PKZ01-G                  | IP65              | -             | -           | -            | ●             | -           | ●               | ●                | ●      |
|  |                            |                   |               | ●           | -            | ●             | -           | ●               | ●                | ●      |
|  | E-PKZ01-PVT<br>E-PKZ01-PVS | IP65              | Red-yellow    | -           | -            | ●             | -           | -               | ●                | ●      |
|  |                            |                   |               | -           | -            | -             | -           | ●               | ●                | ●      |
|  | E-PKZ01-SVB                | IP65              | -             | -           | -            | ●             | -           | -               | ●                | ●      |
|  | E-PKZ01-SVB-V              | IP65              | -             | -           | -            | -             | -           | ● <sup>1)</sup> | ●                | ●      |
| <b>Motor-protective circuit-breaker PKZM0</b>  |                            |                   |               |             |              |               |             |                 |                  |        |
|  | E-PKZ0                     | IP40              | -             | ●           | -            | -             | -           | -               | -                | ●      |
|  |                            |                   |               | -           | -            | -             | -           | -               | ●                | ●      |
|  | E-PKZ0-G                   | IP55              | Black         | ●           | -            | ●             | -           | -               | -                | ●      |
|  |                            |                   |               | -           | -            | ●             | -           | -               | ●                | ●      |
|  | E-PKZ01-GR                 | IP55              | Red-yellow    | ●           | -            | ●             | -           | -               | -                | ●      |
|  |                            |                   |               | -           | -            | ●             | -           | -               | ●                | ●      |

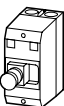
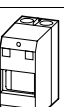
Notes

The combination possibilities of circuit-breakers in an enclosure with accessory modules are identified by a ●  
<sup>1)</sup> always necessary









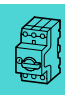

|   |  | Protection type              | For use with   | Part no.<br>Article no.         | Price<br>see price list | Std. pack |  |
|---|--|------------------------------|--|---------------------------------|-------------------------|-----------|--|
| <b>Insulated enclosures for surface mounting</b>                                    |  |                              |  |                                 |                         |           |  |
| For PKZM01 motor-protective circuit-breakers  |  |                              |  |                                 |                         |           |  |
|    |  | IP40                         | PKZM01+NHI-E or VHI-PKZ01+U or A or NHI+L (2 off)                                | <b>CI-PKZ01</b><br>281403       |                         | 1 off     | Integrated terminal for PE(N) connection, two M25 cable entry knockouts at top and at bottom.  |
|    | With actuation membrane  | IP65                         |  | <b>CI-PKZ01-G</b><br>281404     |                         |           |  |
|    | Lockable in off position   |                              | PKZM01+NHI-E or +U or A (undervoltage or shunt release)+L (2 off)                | <b>CI-PKZ01-SVB</b><br>281405   |                         |           |  |
|   | Lockable in off position in combination with VHI-PKZ01   |                              |  | <b>CI-PKZ01-SVB-V</b><br>281944 |                         | 1 off     |  |
|    | With emergency-stop push button actuator, stay-put   |                              |  | <b>CI-PKZ01-PVT</b><br>281406   |                         | 1 off     |  |
|   | With emergency-stop push button actuator, release with key   |                              |  | <b>CI-PKZ01-PVS</b><br>281407   |                         |           |  |
|   | For extension of CI/E-PKZ01-X... unit  | as unit                      | PKZM01   | <b>CI-PKZ01-X</b><br>289934     |                         | 1 off     | Integrated terminal for PE(N) connection, two M25 cable entry knockouts at top and at bottom.  |
| For PKZM0 motor-protective circuit-breakers   |  |                              |  |                                 |                         |           |  |
|  | Cover with aperture dimensioned to accommodate front of breaker. IP40, when mounted turned through | IP41 when mounted vertically | PKZM0-...+NHI or AGM+U or A (undervoltage or shunt release)+NHI-E+L-PKZ0 (2 off) | <b>CI-K2-PKZ0</b><br>219653     |                         | 1 off     | M25 metric cable entry knockout, top and bottom<br>Push-through cable entry diaphragm top, bottom, in the back plate and for control cable entry.<br>CI-K2 insulated enclosure includes N and PE terminal. |
|  | With black/grey rotary handle  | IP65                         |  | <b>CI-K2-PKZ0-G</b><br>219654   |                         |           |  |
|   | With red/yellow rotary handle for use as emergency-stop switches to IEC/EN 60204                   |                              |  | <b>CI-K2-PKZ0-GR</b><br>219655  |                         |           |  |
|  | Cover with aperture dimensioned to accommodate front of breaker                                    | IP40                         | PKZM0-...+NHI or U or A+L-PKZ0 (2 off)   | <b>CI-PKZ0-M</b><br>267083      |                         |           | Integrated terminal for PE(N) connection, two M25 cable entry knockouts at top and at bottom.  |
|  | With black/grey rotary handle  | IP55                         | PKZM0-...+NHI-E+L-PKZ0 (2 off)   | <b>CI-PKZ0-GM</b><br>260089     |                         | 1 off     |  |
|   | With red/yellow rotary handle for use as emergency-stop switches to IEC/EN 60204                   |                              |  | <b>CI-PKZ0-GRM</b><br>260104    |                         |           |  |
| For PKZM0 motor-protective circuit-breakers with early-make VHI auxiliary contacts  |  |                              |  |                                 |                         |           |  |
|  | With black/grey rotary handle  | IP65                         | +NHI or AGM+U or A+L-PKZ0 (2 off)  | <b>CI-K2-PKZ0-GV</b><br>219657  |                         | 1 off     | M25 metric cable entry knockout, top and bottom<br>Push-through cable entry diaphragm top, bottom, in the back plate and for control cable entry.<br>CI-K2 insulated enclosure includes N and PE terminal. |
|   | With red/yellow rotary handle for use as emergency-stop switches to IEC/EN 60204                   |                              |  | <b>CI-K2-PKZ0-GRV</b><br>219656 |                         |           |  |
|  | With black/grey rotary handle  | IP55                         | PKZM0-... and VHI+U or A (undervoltage or shunt release)+L-PKZ0 (2 off)          | <b>CI-PKZ0-GVM</b><br>263526    |                         | 1 off     | Integrated terminal for PE(N) connection, two M25 cable entry knockouts at top and at bottom.  |
|   | With red/yellow rotary handle for use as emergency-stop switches to IEC/EN 60204                   |                              |  | <b>CI-PKZ0-GRVM</b><br>263525   |                         |           |  |

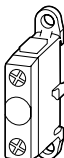
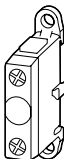

|   | Protection type   | For use with | Part no. Article no.                                     | Price see price list           | Std. pack |   |
|---|---|--------------|--|--------------------------------|-----------|---|
| <b>For PKZM4 motor-protective circuit-breakers</b>  |   |              |  |                                |           |   |
|   | With black/grey rotary handle   | IP65         | +VHI or NHI-E  | <b>CI-K4-PKZ4-G</b><br>225524  | 1 off     | Metric knockout:<br>top and bottom: M25/M32<br>in the back plate: M25/M32<br>Control cable entry: M20<br>CI-K4 insulated enclosure<br>including insulated PE terminal |
|   | With red/yellow rotary handle for use as Emergency-Stop switches to IEC/EN 60204          | IP65         | +NHI or AGM<br>+U or A<br>+L-PKZ0 (2 off)                | <b>CI-K4-PKZ4-GR</b><br>225525 | 1 off     |   |
| <b>Insulated enclosures for flush mounting</b>      |   |              |  |                                |           |   |
| <b>For PKZM01 motor-protective circuit-breakers</b> |   |              |  |                                |           |   |
|   |   | Front IP40   | PKZM01<br>+ NHI or U or A<br>+NHI-E or VHI<br>+L (2 off) | <b>E-PKZ01</b><br>281633       | 1 off     | Integrated terminal for PE(N)<br>connection.  |
|   | With actuation membrane   | Front IP65   |  | <b>E-PKZ01-G</b><br>281634     |           |   |
|   | Lockable in off position  |              | PKZM01<br>+U or A<br>+L (2 off)                          | <b>E-PKZ01-SVB</b><br>281635   |           |   |
|   | Lockable in off position in combination with VHI-PKZ01                                    |              | PKZM01<br>+U or A<br>+NHI-E or VHI<br>+L (2 off)         | <b>E-PKZ01-SVB-V</b><br>281943 |           |   |
|   | With Emergency-Stop push button actuator, stay-put  |              | PKZM01<br>+NHI-E or VHI-PKZ01<br>+U or A<br>+L (2 off)   | <b>E-PKZ01-PVT</b><br>281636   |           |   |
|   | With Emergency-Stop push button actuator, release with key                                |              |  | <b>E-PKZ01-PVS</b><br>281637   |           |   |
|   | For extension of CI/E-PKZ01-X... units  | as unit      | PKZM01   | <b>E-PKZ01-X</b><br>289935     |           |   |
| <b>For PKZM0 motor-protective circuit-breakers</b>  |   |              |  |                                |           |   |
|   | Cover with aperture dimensioned to accommodate front of breaker                           | Front IP40   | PKZM0-... +NHI or U or A<br>+L-PKZ0 (2 off)              | <b>E-PKZ0</b><br>072906        | 1 off     | Integrated terminal for PE(N)<br>connection.  |
|   | With black/grey rotary handle   | Front IP55   | PKZM0-...<br>+NHI or U or A<br>+NHI-E<br>+L-PKZ0 (2 off) | <b>E-PKZ0-G</b><br>072907      |           |   |
|   | With red-yellow rotary knob, for use as EMERGENCY STOP switch in accordance with EN 60204 |              |  | <b>E-PKZ0-GR</b><br>072908     |           |   |



Motor-protective circuit-breakers  
PKZM01, PKZM0, PKZM4



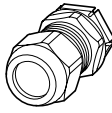

|   | Protection type  | For use with                               | Part no.<br>Article no.                           | Price<br>see price list            | Std. pack |
|---|--|--|---|------------------------------------|-----------|
| <b>Insulated enclosures for surface mounting</b>  |  |  |   |                                    |           |
| Padlocking feature<br>For up to 3 padlocks with 3 – 6 mm hasp thickness, for use as main switch to IEC/EN 60204 |  |  |   |                                    |           |
|                                | Lockable in the 0-position of the PKZM0 or PKZM4 motor-protective circuit-breaker. | CI-K2-PKZ0-G(R)(V)<br>CI-PKZ0-G(R)(V)M     | <b>SVB-PKZ0-CI</b><br>035129                      |                                    | 3 off     |
|   |  | CI-K4-PKZ4-G(R)                            | <b>SVB-PKZ4-CI</b><br>225526                      |                                    | 1 off     |
|   |  | E-PKZ0-G(R)                                | <b>SVB-PKZ0-E</b><br>035127                       |                                    | 3 off     |
| <b>Neutral terminal</b><br>For connection of a 5th conductor  |  |  |   |                                    |           |
|                                | Flexible, 1 – 4 mm <sup>2</sup>  | CI-K2-PKZ0-...                             | <b>K-CI-K1/2</b><br>207451                        |                                    | 20 off    |
|                                | 63 A, flexible, 6 – 16 mm <sup>2</sup>   | CI-K4-PKZ4-G(R)                            | <b>K25/1</b><br>096200                            |                                    | 10 off    |
|                                |  | E-PKZ0(-G)(-GR)<br>E-PKZ01(-G)             | <b>N-PKZ0</b><br>082160                           |                                    | 20 off    |
| <b>Units for insulated enclosures for PKZ01</b>   |  |  |   |                                    |           |
| Can be combined with CI-PKZ01-X and E-PKZ01-X.  |  |  |   |                                    |           |
|                              | With operating membrane  | Front IP65                                 | PKZM01+NHI-E or VHI-PKZ01+U or A or NHI+L (2 off) | <b>CI/E-PKZ01-XG</b><br>289936     | 1 off     |
|                              | Can be locked in 0 position  |  | PKZM01+NHI-E+U or A+L (2 off)                     | <b>CI/E-PKZ01-XSVB</b><br>289939   |           |
|                              | Lockable in off position in combination with VHI-PKZ01                             |  | PKZM01VHI-PKZ01+U or A+L (2 off)                  | <b>CI/E-PKZ01-XSVB-V</b><br>289980 |           |
|                              | With Emergency-Stop mushroom-headed pushbutton, stay-put                           |  | PKZM01+NHI-E or VHI-PKZ01+U or A+L (2 off)        | <b>CI/E-PKZ01-XPVT</b><br>289937   |           |
|   | With EMERGENCY STOP mushroom-headed pushbutton, with key-release                   | PKZM01+NHI-E or VHI-PKZ01+U or A+L (2 off) | <b>CI/E-PKZ01-XPVS</b><br>289938                  |                                    |           |

http://catalog.moeller.net

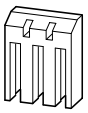

Moeller HPL0211-2007/2008

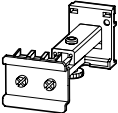
| Cable entry  | Hole diameter<br>mm   | External diameter<br>of cable<br>mm | Part no.<br>Article no. | Price<br>see price<br>list | Std. pack |  |
|--|---|-------------------------------------|-------------------------|----------------------------|-----------|--|
| <b>Metric cable glands to EN 50262</b>   |   |                                     |                         |                            |           |  |
| <ul style="list-style-type: none"> <li>• With lock nut and integral strain relief</li> <li>• IP68 up to 5 bar, halogen free</li> </ul> |   |                                     |                         |                            |           |  |
|   | M20   | 20.5                                | 6 – 13                  | V-M20<br>206910            | 20 off    |  |
|  | M25   | 25.5                                | 9 – 17                  | V-M25<br>206911            |           |  |
|  | M32   | 32.5                                | 13 – 21                 | V-M32<br>206912            |           |  |
|  | M32   | 32.5                                | 18 – 25                 | V-M32G<br>226156           |           |  |
| <b>Metric diaphragm grommets</b>   |   |                                     |                         |                            |           |  |
| <ul style="list-style-type: none"> <li>• IP65</li> <li>• With integral push-through diaphragm</li> </ul>                               |   |                                     |                         |                            |           |  |
|   | M20   | 20.5                                | 1 – 13                  | KT-M20<br>207602           | 100 off   |  |
|  | M25   | 25.5                                | 1 – 18                  | KT-M25<br>207603           |           |  |
|  | M32   | 32.5                                | 1 – 24                  | KT-M32<br>207604           |           |  |
| <b>Door coupling handle IP65</b>   |   |                                     |                         |                            |           |  |
| Can be used with PKZM0 and PKZM4   |   |                                     |                         |                            |           |  |
|   | For use as main switch to IEC/EN 60204  | Black                               |                         | PKZ0-XH<br>106132          | 1 off     | Plug-in extension shaft A-H-PKZ0 can be cut to desired length for mounting depths of 100 – 240 mm. Carrier with extension shaft included in delivery. With ON/OFF switch position and "+" (tripped), lockable. With 3 padlocks, 4 – 8 mm hasp. Prepared for locking in ON. |
|  | For use as a main switch with Emergency-Stop function, to EN 60204  | Red-yellow                          |                         | PKZ0-XRH<br>106133         |           |  |
|  | For use as a main switch to EN 60204 in MCC power distribution systems and with PKZM0 installed when rotated by 90°                         | Black                               |                         | PKZ0-XH-MCC<br>106136      |           |  |
|  | For use as a main switch with Emergency-Stop function to EN 60204 in MCC power distribution systems and with PKZM0 installed rotated by 90° | Red-yellow                          |                         | PKZ0-XRH-MCC<br>106137     |           |  |
| <b>Terminal shroud</b>   |   |                                     |                         |                            |           |  |
|   | For enhancement of the degree of protection of the PKZM4 to IP2x  |                                     | PKZM4                   | HB-PKZ4<br>256581          | 1 off     |  |

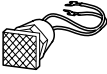

|   | Part no.<br>Article no.   | Price<br>see price<br>list        | Std. pack   |
|---|---|-----------------------------------|---|
| <b>Telescopic adapters</b>  |   |                                   |   |
| With 45 mm top-hat rail to IEC/EN 60715, for compensating of the mounting depth of rear mounted devices in CI-K.. enclosures and cabinets.              |   |                                   |   |
|    | Telescopic adapter  | <b>M22-TA</b><br>226161           | 1 off<br>Steplessly adjustable by means of a scale, from 75 – 115 mm. |
| <b>Lockable rotary handle</b>   |   |                                   |   |
|    | For connection of the motor-protective circuit-breaker PKZM0 and PKZM4 as a main switch to EN 60204. Can be padlocked in the "0" position with a padlock. Hasp thickness: 3 – 6.35 mm         | <b>AK-PKZO</b><br>030851          | 5 off<br>Cannot be combined with VHI-PKZO.                            |
| <b>Sealing facility</b>   |   |                                   |   |
|   | To prevent tampering with the overload release and the test function, it can be sealed using industry standard sealing wire<br>For use with motor-protective circuit-breakers PKZM0 and PKZM4 | <b>PL-PKZO</b><br>203599          | 5 off   |
| <b>Documentation</b>  |   |                                   |   |
|   | PKZM0 motor-protective circuit-breakers, overload monitoring of EEx e motors  | <b>AWB1210-1458D/GB</b><br>266164 | 1 off<br>German/English   |
|   | PKZM4 motor-protective circuit-breakers, overload monitoring of EEx e motors  | <b>AWB1210-1457D/GB</b><br>266165 | 1 off<br>German/English   |
| <b>Blade terminal to DIN 46244</b>  |   |                                   |   |
| For connection of insulated ferrules for:<br>main cables up to 25 A, 1 × 6.3 mm (DIN 46245)<br>control circuit cables up to 6 A, 2 × 2.8 mm (DIN 46247) |   |                                   |   |
|    |   | <b>BT483</b><br>059904            | 100 off<br>Use insulated ferrules to DIN 46245.                       |

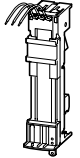
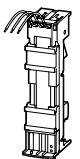
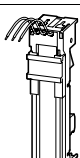
|   | Colour | Voltage<br><br>V | Part no.<br>Article no.          | Price<br>see price<br>list | Std. pack |
|---|--------|------------------|----------------------------------|----------------------------|-----------|
| <b>Indicator lights with neon bulb</b>  |        |                  |                                  |                            |           |
|  | white  | 110 – 230        | <b>L-PKZO(230V)</b><br>082151    |                            | 10 off    |
|   |        | 230 – 400        | <b>L-PKZO(400V)</b><br>082152    |                            | 10 off    |
|   |        | 415 – 500        | <b>L-PKZO(500V)</b><br>082153    |                            | 5 off     |
|   | green  | 110 – 230        | <b>L-PKZO-GN(230V)</b><br>082154 |                            | 10 off    |
|   |        | 230 – 400        | <b>L-PKZO-GN(400V)</b><br>082155 |                            | 10 off    |
|   |        | 415 – 500        | <b>L-PKZO-GN(500V)</b><br>082156 |                            | 5 off     |
|   | red    | 110 – 230        | <b>L-PKZO-RT(230V)</b><br>082157 |                            | 10 off    |
|   |        | 230 – 400        | <b>L-PKZO-RT(400V)</b><br>082158 |                            | 10 off    |

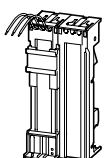
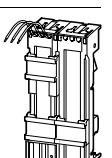
|  | Rated operation voltage<br>$U_e$<br>V | Rated operation current<br>$I_e$<br>A | Terminal capacity           | Adapter width<br>mm | Adapter length<br>mm | DIN rail<br>Quantity | For use with   | Part no.<br>Article no.   | Price<br>see price list | Std. pack | Notes   |
|--|---------------------------------------|---------------------------------------|-----------------------------|---------------------|----------------------|----------------------|--|---------------------------|-------------------------|-----------|---|
| <b>Component adapter, 3 pole</b>   |                                       |                                       |                             |                     |                      |                      |  |                           |                         |           |   |
| Approved to UL 508.<br>For fitting to flat Cu-busbars with 60 mm between busbar centres, suitable for 5 mm and 10 mm busbar thickness. |                                       |                                       |                             |                     |                      |                      |  |                           |                         |           |   |
| For direct-on-line starters  |                                       |                                       |                             |                     |                      |                      |  |                           |                         |           |   |
|   | 690                                   | 25                                    | AWG 12 (4 mm <sup>2</sup> ) | 45                  | 200                  | 1                    | PKZM0 + DILM7<br>PKZM0 + DILM9<br>PKZM0 + DILM12<br>PKZM0 + DILM15<br>MSC-D-0,25-M7...<br>bis MSC-D-16-M15...                      | <b>BBA0-25</b><br>101451  |                         | 4         | In combination with individual components PKZM0 and DILM DOL starter use PKZM0-XDM12.   |
|   | 690                                   | 32                                    | AWG 10 (6 mm <sup>2</sup> ) | 45                  | 200                  | 2                    | PKZM0 + DILM17<br>PKZM0 + DILM25<br>PKZM0 + DILM32<br>MSC-D-16-M17...<br>bis MSC-D-32-M32...                                       | <b>BBA0-32</b><br>101452  |                         |           | In combination with individual components PKZM0 and DILM use electrical contact module PKZM0 XM32DE.                                      |
|    | 690                                   | 63                                    | AWG 8 (10 mm <sup>2</sup> ) | 55                  | 260                  | 2                    | PKZM4 + DILM17<br>PKZM4 + DILM25<br>PKZM4 + DILM32<br>PKZM4 + DILM40<br>PKZM4 + DILM50<br>PKZM4 + DILM65                           | <b>BBA4L-63</b><br>101459 |                         |           | For electrical connection for PKZM4 + DILM17 – DILM32: MVS-LB0-0M-G<br>PKZM4 + DILM40 – DILM65: PKZM4-XM65DE can be used.                 |
|   | 690                                   | 63                                    | AWG 8 (10 mm <sup>2</sup> ) | 72                  | 260                  | 2                    | PKZ2 + DILM7<br>PKZ2 + DILM9<br>PKZ2 + DILM12<br>PKZ2 + DILM15<br>PKZ2 + DILM17<br>PKZ2 + DILM25<br>PKZ2 + DILM32<br>PKZ2 + DILM40 | <b>BBA2L-63</b><br>101480 |                         |           | For electrical connection for PKZ2 + DILM7 – DILM12: MVS-LB0-00M-G<br>PKZ2 + DILM15 – DILM32: MVS-LB0-0M-G can be used.                   |
| For reversing starters   |                                       |                                       |                             |                     |                      |                      |  |                           |                         |           |   |
|   | 690                                   | 25                                    | AWG 12 (4 mm <sup>2</sup> ) | 90                  | 200                  | 1                    | PKZM0 + 2 × DILM7-01<br>PKZM0 + 2 × DILM9-01<br>PKZM0 + 2 × DILM12-01<br>MSC-R-0,25-M7...<br>bis MSC-R-12-M12...                   | <b>BBA0R-25</b><br>101453 |                         | 2         | In combination with individual components PKZM0 and DILM DOL reversing starter use PKZM0-XRM12.   |
|   | 690                                   | 32                                    | AWG 10 (6 mm <sup>2</sup> ) | 90                  | 200                  | 2                    | PKZM0 + 2 × DILM17-01<br>PKZM0 + 2 × DILM25-01<br>PKZM0 + 2 × DILM32-01<br>MSC-R-16-M17...<br>bis MSC-R-32-M32...                  | <b>BBA0R-32</b><br>101454 |                         | 2         | In combination with individual components PKZM0 and DILM use electrical contact module PKZM0 XM32DE and reversing wiring set DILM 32-XRL. |



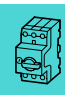

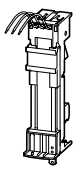
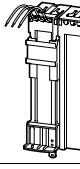
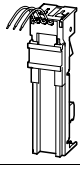
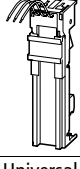
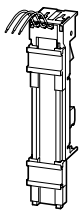
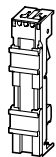
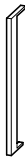
Motor-protective circuit-breakers  
PKZM01, PKZM0, PKZM4





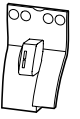

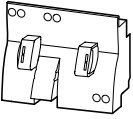
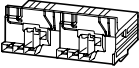
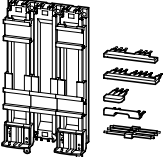
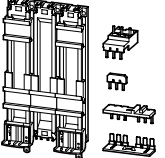
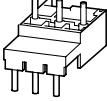
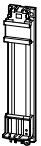



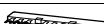
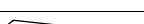
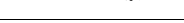

|  | Rated operation al voltage<br>$U_e$<br>V | Rated operation al current<br>$I_e$<br>A | Terminal capacity                | Adap-ter width<br>mm | Adap-ter length<br>mm | DIN rail<br>Quantity | For use with   | Part no.<br>Article no.      | Price<br>see price list | Std. pack | Notes   |
|--|--|--|----------------------------------|----------------------|-----------------------|----------------------|--|------------------------------|-------------------------|-----------|---|
| <b>Component adapter, 3 pole</b>   |  |  |                                  |                      |                       |                      |  |                              |                         |           |   |
| Approved to UL 508.<br>For fitting to flat Cu-busbars with 60 mm between busbar centres, suitable for 5 mm and 10 mm busbar thickness. |  |  |                                  |                      |                       |                      |  |                              |                         |           |   |
| For starters with springloaded terminals   |  |  |                                  |                      |                       |                      |  |                              |                         |           |   |
|   | 690                                      | 16                                       | AWG 14<br>(2.5 mm <sup>2</sup> ) | 45                   | 200                   | 2                    | PKZM0-C + DILMC7<br>PKZM0-C + DILMC9<br>PKZM0-C + DILMC12                      | <b>BBA0C-16</b><br>101455    |                         | 4 off     | According to UL 508: $I_e = 12$ A   |
|   | 690                                      | 16                                       | AWG 14<br>(2.5 mm <sup>2</sup> ) | 90                   | 200                   | 2                    | PKZM0-C + 2 × DILMC7-01<br>PKZM0-C + 2 × DILMC9-01<br>PKZM0-C + 2 × DILMC12-01 | <b>BBA0RC-16</b><br>101456   |                         | 2 off     | According to UL 508: $I_e = 12$ A   |
| <b>Motor-protective circuit-breakers</b>   |  |  |                                  |                      |                       |                      |  |                              |                         |           |   |
|    | 690                                      | 63                                       | AWG 8<br>(10 mm <sup>2</sup> )   | 54                   | 200                   | 1                    | PKZM4  | <b>BBA4-63</b><br>101457     |                         | 4 off     |   |
|   | 690                                      | 63                                       | AWG 8<br>(10 mm <sup>2</sup> )   | 72                   | 200                   | 1                    | PKZ2   | <b>BBA2-63</b><br>101458     |                         | 4 off     |   |
| <b>Universal adapter</b><br>For universal use  |  |  |                                  |                      |                       |                      |  |                              |                         |           |   |
|   | 690                                      | 25                                       | AWG 12<br>(4 mm <sup>2</sup> )   | 45                   | 200                   | 2                    |  | <b>BBA0-25/2TS</b><br>101481 |                         | 4 off     | Mounting rail can be offset on 1.25 mm grid.  |
| <b>Empty module</b><br>Without electrical contacts   |  |  |                                  |                      |                       |                      |  |                              |                         |           |   |
|   |  |  |                                  | 45                   | 200                   | 2                    |  | <b>BBA0/2TS-L</b><br>101482  |                         | 4 off     | Mounting rail can be offset on 1.25 mm grid.<br>For use with implementation of reversing and star-delta starters. |
|  |  |  |                                  | 54                   | 200                   | 2                    |  | <b>BBA4/2TS-L</b><br>101483  |                         | 4 off     |   |
| <b>Side mounted module</b><br>Can be plugged into both sides   |  |  |                                  |                      |                       |                      |  |                              |                         |           |   |
|   |  |  |                                  | 9                    | 200                   |                      |  | <b>BBA-XSM</b><br>101484     |                         | 10 off    | Can be grouped on the busbar adapter to extend mounting width   |

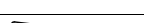

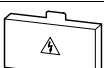
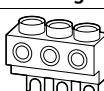

|   | For use with   | Part no.<br>Article no.       | Price<br>see price<br>list | Std. pack | Notes   |
|---|--|-------------------------------|----------------------------|-----------|---|
| <b>Wiring set</b>   |  |                               |                            |           |   |
| <b>DOL starters</b>   |  |                               |                            |           |   |
|    | PKZM0 + DILM7<br>PKZM0 + DILM9<br>PKZM0 + DILM12<br>PKZM0 + DILM15 | <b>PKZM0-XDM12</b><br>283149  |                            | 1 off     | Comprised of:<br>• Mechanical connection element for PKZM0 and contactor<br>• Main current wiring between PKZM0 and contactor in tool-less plug connection<br>• Cable routing<br>As auxiliary contact DILA-XHIT...use → 5/29  |
|    | PKZM0 + DILM17<br>PKZM0 + DILM25<br>PKZM0 + DILM32                 | <b>PKZM0-XDM32</b><br>283153  |                            | 1 off     | Comprised of:<br>• Top-hat rail adapter plate<br>• Main current wiring between PKZ and contactor  |
| <b>Reversing starters</b>   |  |                               |                            |           |   |
|    | PKZM0 + DILM7-01<br>PKZM0 + DILM9-01<br>PKZM0 + DILM12-01          | <b>PKZM0-XRM12</b><br>283185  |                            | 1 off     | Comprised of:<br>• Mechanical connection element for PKZM0 and contactor<br>• Reversing starter main current wiring in tool-less plug connection<br>• Control cables for electrical interlocking in tool-less plug connection:<br>– K1M: A1 –K2M: 21<br>– K1M: 21 –K2M: A1<br>– K1M: A2 –K2M: A2<br>• Cable routing<br>As auxiliary contact DILA-XHIT...use → 5/29<br>Cannot be combined with AGM-PKZ0. |
|    | PKZM0 + DILM17<br>PKZM0 + DILM25<br>PKZM0 + DILM32                 | <b>PKZM0-XRM32</b><br>283189  |                            | 1 off     | Comprised of:<br>• Top-hat rail adapter plate<br>• Reversing starter main current wiring  |
| <b>Star-delta starter</b>   |  |                               |                            |           |   |
|  | PKZM0 + DILM7<br>PKZM0 + DILM9<br>PKZM0 + DILM12<br>PKZM0 + DILM15 | <b>PKZM0-XSM12</b><br>239346  |                            | 1 off     | Comprised of:<br>• Top-hat rail adapter plate<br>• Main current wiring between PKZM0 and contactor<br>• Electrical interlock between delta and star contactor<br>• Use as contactor auxiliary switch DILA-XHIT... → 5/29  |
|  | PKZM0 + DILM17<br>PKZM0 + DILM25<br>PKZM0 + DILM32                 | <b>PKZM0-XSM32</b><br>239347  |                            | 1 off     | Comprised of:<br>• Top-hat rail adapter plate<br>• Main current wiring between PKZM0 and contactor  |
| <b>Electric contact module</b>  |  |                               |                            |           |   |
|  | PKZM0 + DILM17<br>PKZM0 + DILM25<br>PKZM0 + DILM32                 | <b>PKZM0-XM32DE</b><br>239349 |                            | 5 off     | • Main current wiring between PKZM0 and contactor<br>• Use only in combination with busbar adapter  |
|   | PKZM4 + DILM40<br>PKZM4 + DILM50<br>PKZM4 + DILM65                 | <b>PKZM4-XM65DE</b><br>101056 |                            | 5 off     | • Main current wiring between PKZM4 and contactor<br>• Use only in combination with busbar adapter  |
| <b>Top-hat rail adapter plate</b>   |  |                               |                            |           |   |
|  | PKZM0-XDM12<br>PKZM0-XRM12   | <b>PKZM0-XC45</b><br>283132   |                            | 4 off     | Comprised of:<br>• 45 mm wide adapter plate<br>• Connection element for side-by-side positioning of further plates  |
|  | PKZM4 + DILM40<br>PKZM4 + DILM50<br>PKZM4 + DILM65                 | <b>PKZM4-XC55/2</b><br>101054 |                            | 4 off     | Comprised of:<br>• 55 mm wide adapter plate<br>• Connection cams for further plates<br>• For use with reversing and star-delta starters   |
| Side mounted module   |  | <b>PKZM0-XS</b><br>239354     |                            | 10 off    | Can be grouped on the top-hat rail adapter<br>Expansion of the mounting width by 9 mm.  |
| Connection element  |  | <b>PKZM0-XCM</b><br>239359    |                            | 50 off    | For connection of several top-hat rail adapter  |

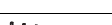
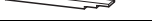

| Circuit-breaker   | Length | Unit width | Part no.<br>Article no. | Price<br>see price<br>list     | Std. pack | Notes   |
|---|--------|------------|-------------------------|--------------------------------|-----------|---|
| Number  | mm     | mm         |                         |                                |           |   |
| <b>Three phase commoning link, power feed to terminals 1, 3, 5</b>  |        |            |                         |                                |           |   |
| Protection against direct contact (touch-proof), $U_e = 690\text{ V}$ , $I_u = 63\text{ A}$<br>can be lengthened by rotated mounting      |        |            |                         |                                |           |   |
| For PKZM0-... without side mounted auxiliary contacts or voltage releases   |        |            |                         |                                |           |   |
|    | 2      | 90         | 45                      | <b>B3.0/2-PKZO</b><br>063961   | 10 off    | For parallel power feed to several motor-protective circuit-breakers on terminals 1, 3, 5   |
|    | 3      | 135        | 45                      | <b>B3.0/3-PKZO</b><br>232289   |           |   |
|    | 4      | 180        | 45                      | <b>B3.0/4-PKZO</b><br>063960   |           |   |
|    | 5      | 225        | 45                      | <b>B3.0/5-PKZO</b><br>232290   |           |   |
| For motor-protective circuit-breaker each with an auxiliary contact or trip-indicating auxiliary contact fitted on the right              |        |            |                         |                                |           |   |
|    | 2      | 99         | 45 + 9                  | <b>B3.1/2-PKZO</b><br>044945   | 10 off    | For parallel power feed to several motor-protective circuit-breakers on terminals 1, 3, 5   |
|    | 3      | 153        | 45 + 9                  | <b>B3.1/3-PKZO</b><br>044946   |           |   |
|    | 4      | 207        | 45 + 9                  | <b>B3.1/4-PKZO</b><br>044947   |           |   |
|    | 5      | 261        | 45 + 9                  | <b>B3.1/5-PKZO</b><br>044948   |           |   |
| For PKZM0-... with one auxiliary contact each and a trip-indicating auxiliary contact fitted on right or a voltage release fitted on left |        |            |                         |                                |           |   |
|    | 2      | 108        | 45 + 18                 | <b>B3.2/2-PKZO</b><br>063963   | 10 off    | For parallel power feed to several motor-protective circuit-breakers on terminals 1, 3, 5   |
|    | 4      | 234        | 45 + 18                 | <b>B3.2/4-PKZO</b><br>063959   | 10 off    |   |
| <b>Shroud for unused terminals</b>  |        |            |                         |                                |           |   |
| Protection against direct contact.<br>For closing off non-used connections on the three phase commoning link B3...-PKZO                   |        |            |                         |                                |           |   |
|    |        |            |                         | <b>H-B3-PKZO</b><br>032721     | 20 off    |   |
| <b>Incoming terminal</b>  |        |            |                         |                                |           |   |
|    |        |            |                         | <b>BK25/3-PKZO</b><br>032720   | 5 off     | For three-phase commoning link, protected against accidental contact, $U_e = 690\text{ V}$ , $I_u = 63\text{ A}$<br>For conductor cross-sections:<br>2.5 – 25 mm <sup>2</sup> stranded<br>2.5 – 16 mm <sup>2</sup> flexible with ferrules<br>AWG 14 – 6, for use on terminals 1, 3, 5 |
| <b>Three phase commoning link, power feed to terminals 2, 4, 6</b>  |        |            |                         |                                |           |   |
| Protection against direct contact (touch-proof), $U_e = 690\text{ V}$ , $I_u = 63\text{ A}$<br>can be lengthened by rotated mounting      |        |            |                         |                                |           |   |
| For PKZM0-... without side mounted auxiliary contacts or voltage releases   |        |            |                         |                                |           |   |
|    | 2      | 90         | 45                      | <b>B3.0/2-PKZO-U</b><br>292387 | 5 off     | For parallel power feed to several motor-protective circuit-breakers on terminals 2, 4, 6   |
|    | 3      | 135        | 45                      | <b>B3.0/3-PKZO-U</b><br>292388 |           |   |
|    | 4      | 180        | 45                      | <b>B3.0/4-PKZO-U</b><br>292389 |           |   |
|    | 5      | 225        | 45                      | <b>B3.0/5-PKZO-U</b><br>292880 |           |   |



Three-phase commoning links

http://catalog.moeller.net

Moeller HPL0211-2007/2008

B3...PKZ0-U, B3...-PKZ4



Motor-protective circuit-breakers  
PKZM01, PKZM0, PKZM4

|  | Circuit-breaker Number | Length mm | Unit width mm | Part no. Article no.    | Price see price list | Std. pack |   |
|--|------------------------|-----------|---------------|-------------------------|----------------------|-----------|---|
| For motor-protective circuit-breaker each with an auxiliary contact or trip-indicating auxiliary contact fitted on the right       |                        |           |               |                         |                      |           |   |
|  | 2                      | 99        | 45 + 9        | B3.1/2-PKZ0-U<br>292881 |                      | 5 off     | For parallel power feed to several motor-protective circuit-breakers on terminals 2, 4, 6   |
|  | 3                      | 153       | 45 + 9        | B3.1/3-PKZ0-U<br>292882 |                      |           |   |
|  | 4                      | 207       | 45 + 9        | B3.1/4-PKZ0-U<br>292883 |                      |           |   |
|  | 5                      | 261       | 45 + 9        | B3.1/5-PKZ0-U<br>292884 |                      |           |   |
| <b>Shroud for unused terminals</b>   |                        |           |               |                         |                      |           |   |
| Protection against direct contact.<br>For closing off non-used connections on the three phase commoning link B3...-PKZ0-U          |                        |           |               |                         |                      |           |   |
|  |                        |           |               | H-B3-PKZ0-U<br>292885   |                      | 10 off    |   |
| <b>Incoming terminal</b>   |                        |           |               |                         |                      |           |   |
|  |                        |           |               | BK25/3-PKZ0-U<br>292886 |                      | 10 off    | For three-phase commoning link, protected against accidental contact, $U_e = 690$ V, $I_n = 63$ A<br>For conductor cross-sections: 2.5 – 25 mm <sup>2</sup> stranded<br>2.5 – 16 mm <sup>2</sup> flexible with ferrules<br>For use on the terminals 2, 4, 6 |
| <b>Three-phase commoning link</b>  |                        |           |               |                         |                      |           |   |
| Protection against direct contact (touch-proof), $U_e = 690$ V, $I_n = 128$ A  |                        |           |               |                         |                      |           |   |
| For motor-protective circuit-breakers/(high-capacity) compact starters without side-fitted auxiliary contact or voltage releases   |                        |           |               |                         |                      |           |   |
|  | 2                      | 110       | 55            | B3.0/2-PKZ4<br>220220   |                      | 1 off     |   |
|  | 3                      | 165       |               | B3.0/3-PKZ4<br>220221   |                      |           |   |
|  | 4                      | 220       |               | B3.0/4-PKZ4<br>220222   |                      |           |   |
| For PKZM4 each with an auxiliary contact or trip-indicating auxiliary contact fitted on the right                                  |                        |           |               |                         |                      |           |   |
|  | 2                      | 119       | 55 + 9        | B3.1/2-PKZ4<br>220223   |                      | 1 off     |   |
|  | 3                      | 183       |               | B3.1/3-PKZ4<br>220224   |                      |           |   |
|  | 4                      | 247       |               | B3.1/4-PKZ4<br>220225   |                      |           |   |
| For PKZM4 with one auxiliary contact each or trip-indicating auxiliary contact fitted on right or a voltage release fitted on left |                        |           |               |                         |                      |           |   |
|  | 2                      | 128       | 55 + 18       | B3.2/2-PKZ4<br>220226   |                      | 1 off     |   |
|  | 4                      | 274       | 55 + 18       | B3.2/4-PKZ4<br>220227   |                      | 1 off     |   |
| <b>Shroud for unused terminals</b>   |                        |           |               |                         |                      |           |   |
| Protection against direct contact.<br>To cover unused terminals on three-phase commoning link                                      |                        |           |               |                         |                      |           |   |
|  |                        |           |               | H-B3-PKZ4<br>220228     |                      | 10 off    |   |



## Shunt release, undervoltage release

| AC  | When ordered separately                     |   |
|---|---|---|
|   | A-PKZ0(...)                                 | U-PKZ0(...)                                 |
| Standard voltage  | Article no. <sup>1)</sup><br>see price list | Article no. <sup>1)</sup><br>see price list |
| 24V 50Hz  | 073181                                      | 073129                                      |
| 110V 50Hz   | 073184                                      | 073132                                      |
| 220V 50Hz   | 073186                                      | 073134                                      |
| 230V 50Hz   | 073187                                      | 073135                                      |
| 240V 50Hz   | 073188s                                     | 073136                                      |
| 380V 50Hz   | 073189                                      | 073137                                      |
| 400V 50Hz   | 073190                                      | 073138                                      |
| 415V 50Hz   | 073191                                      | 073139                                      |
| 120V 60Hz   | 073195                                      | 073143                                      |
| 240 V 60 Hz   | 073198                                      | 073146                                      |
| 440V 60Hz   | 082164                                      | 082161                                      |
| 480V 60Hz   | 073199                                      | 073147                                      |
| Non-standard voltages with the exception of the shown standard voltages <sup>2)</sup> . | see price list                              | see price list                              |
| ...V 50Hz (24 – 500V) <sup>3)</sup>   |   | 982162                                      |
| ...V 60Hz (24 – 600V) <sup>3)</sup>   |   | 982163                                      |
| DC  |   |   |
| Standard voltage  | see price list                              | see price list<br>–                         |
| 24V DC  | 073200<br>073203                            | –<br>–                                      |

## Notes

- <sup>1)</sup> The article no. is formed from the combination of part no. and actuating voltage.
- <sup>2)</sup> With non-standard voltages the required actuating voltage from the defined range (...-...V) must be stated.
- <sup>3)</sup> Minimum order quantity: 10 off



Motor protection, system protection, conductor and cable protection

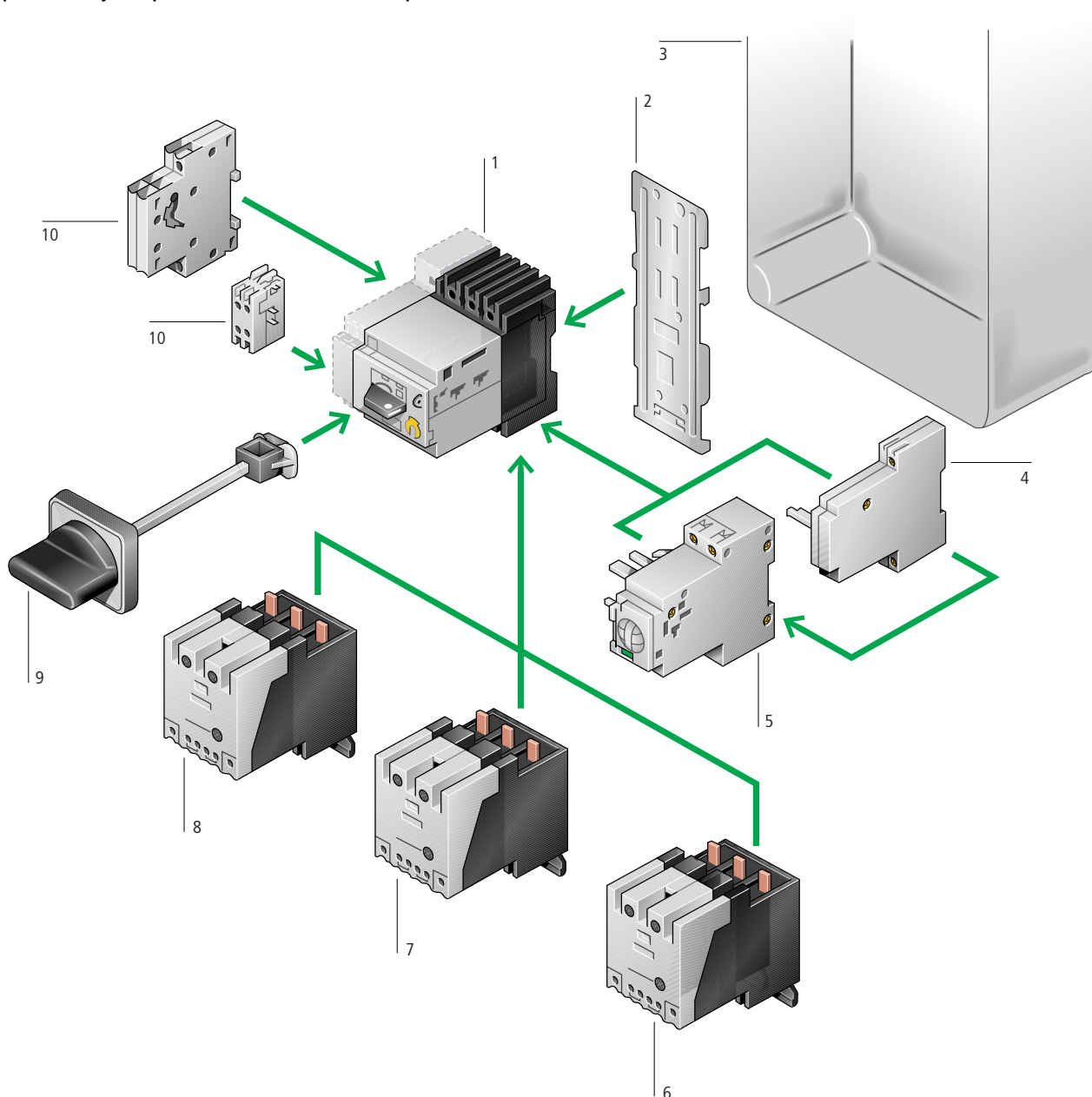

Motor-protective circuit-breakers PKZ2

| Basic units                       |   |
|-----------------------------------|---|
| Motor-protective circuit-breakers | 1 |
| → Page 8/27                       |   |
| Circuit-breakers                  | 1 |
| → Page 8/27                       |   |

| Add-on functions             |    |
|------------------------------|----|
| Contact module               | 6  |
| → Page 8/41                  |    |
| High-capacity contact module | 7  |
| → Page 8/41                  |    |
| Auxiliary contacts           | 10 |
| → Page 8/35                  |    |
| Current limiter              | 8  |
| → Page 8/35                  |    |
| Voltage releases             | 4  |
| → Page 8/37                  |    |
| Remote operators             | 5  |
| → Page 8/39                  |    |

| Mounting accessories      |   |
|---------------------------|---|
| Mounting/wiring           | 2 |
| → Page 8/44               |   |
| Door coupling handle IP65 | 9 |
| → Page 8/33               |   |
| Insulated enclosures      | 3 |
| → Page 8/33               |   |

PKZ2

Moeller HPL0211-2007/2008

http://catalog.moeller.net

| Max. motor rating |       |       |       |       | Rated uninterrupted current<br>$I_u$ | Setting range     |                        |
|-------------------|-------|-------|-------|-------|--------------------------------------|-------------------|------------------------|
| AC-3              |       |       |       |       |                                      | Overload releases | Short-circuit releases |
| 220 V             | 380 V | 440 V | 500 V | 660 V | A                                    | $I_r$             | $I_m$                  |
| 230 V             | 400 V |       |       | 690 V |                                      |                   |                        |
| 240 V             | 415 V |       |       |       |                                      |                   |                        |
| $P$               | $P$   | $P$   | $P$   | $P$   | A                                    | A                 |                        |
| kW                | kW    | kW    | kW    | kW    |                                      |                   |                        |

Motor-protective circuit-breakers, Type "1" and Type "2" coordination

|      |      |      |      |      |     |           |           |
|------|------|------|------|------|-----|-----------|-----------|
| 0.09 | 0.12 | 0.18 | 0.25 | 0.25 | 0.6 | 0.4...0.6 | 5...8     |
| 0.12 | 0.25 | 0.25 | 0.37 | 0.55 | 1   | 0.6...1   | 8...14    |
| 0.25 | 0.55 | 0.55 | 0.75 | 1.1  | 1.6 | 1...1.6   | 14...22   |
| 0.37 | 0.75 | 1.1  | 1.1  | 1.5  | 2.4 | 1.6...2.4 | 20...35   |
| 0.75 | 1.5  | 1.5  | 2.2  | 3    | 4   | 2.4...4   | 35...55   |
| 1.1  | 2.2  | 3    | 3    | 4    | 6   | 4...6     | 50...80   |
| 2.2  | 4    | 4    | 5.5  | 7.5  | 10  | 6...10    | 80...140  |
| 4    | 7.5  | 9    | 9    | 12.5 | 16  | 10...16   | 130...220 |
| 5.5  | 12.5 | 12.5 | 15   | 22   | 25  | 16...25   | 200...350 |
| 7.5  | 15   | 17.5 | 22   | 22   | 32  | 24...32   | 275...425 |
| 11   | 20   | 22   | 24   | 30   | 40  | 32...40   | 350...500 |

Circuit-breakers

| For protection of cables and conductors |   |   |   |   |    |         |           |
|---|---|---|---|---|----|---------|-----------|
| -                                       | - | - | - | - | 10 | 6...10  | 50...80   |
| -                                       | - | - | - | - | 16 | 10...16 | 80...140  |
| -                                       | - | - | - | - | 25 | 16...25 | 130...210 |
| -                                       | - | - | - | - | 32 | 24...32 | 160...280 |
| -                                       | - | - | - | - | 40 | 32...40 | 200...350 |

http://catalog.moeller.net

Moeller HPL0211-2007/2008

PKZ2

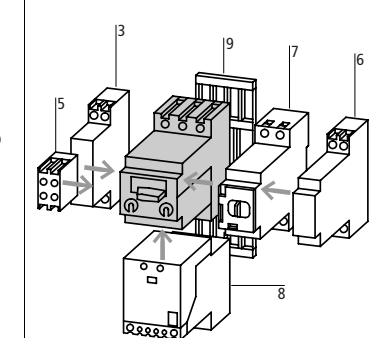
| Part no.<br>Article no.   | Price<br>see price list | Std. pack | Notes   | Notes  |                              |        |                                     |        |                                       |        |                    |        |   |        |              |        |
|---|-------------------------|-----------|---|--|------------------------------|--------|-------------------------------------|--------|---------------------------------------|--------|--------------------|--------|---|--------|--------------|--------|
| PKZ2/ZM-0,6<br>021859   |                         | 1 off     | Single-phasing sensitivity to IEC/EN 60947-4-1  |  <p><b>Accessories</b></p> <table border="0"> <tr><td>3 Standard auxiliary contact</td><td>→ 8/35</td></tr> <tr><td>5 Trip-indicating auxiliary contact</td><td>→ 8/35</td></tr> <tr><td>6 Shunt release, undervoltage release</td><td>→ 8/37</td></tr> <tr><td>7 Remote operators</td><td>→ 8/39</td></tr> <tr><td>8 Contact module, high-capacity contact module, current limiter</td><td>→ 8/41</td></tr> <tr><td>9 Clip plate</td><td>→ 8/44</td></tr> </table> <p>Additional accessories → 8/33</p> <p>Rated ultimate short-circuit breaking capacity Manual → Technical data</p> <p>→ 8/44</p> <p>Can be snap fitted to IEC/EN 60715 with 7.5 or 15 mm height</p> | 3 Standard auxiliary contact | → 8/35 | 5 Trip-indicating auxiliary contact | → 8/35 | 6 Shunt release, undervoltage release | → 8/37 | 7 Remote operators | → 8/39 | 8 Contact module, high-capacity contact module, current limiter | → 8/41 | 9 Clip plate | → 8/44 |
| 3 Standard auxiliary contact                                    | → 8/35                  |           |   |  |                              |        |                                     |        |                                       |        |                    |        |   |        |              |        |
| 5 Trip-indicating auxiliary contact                             | → 8/35                  |           |   |  |                              |        |                                     |        |                                       |        |                    |        |   |        |              |        |
| 6 Shunt release, undervoltage release                           | → 8/37                  |           |   |  |                              |        |                                     |        |                                       |        |                    |        |   |        |              |        |
| 7 Remote operators  | → 8/39                  |           |   |  |                              |        |                                     |        |                                       |        |                    |        |   |        |              |        |
| 8 Contact module, high-capacity contact module, current limiter | → 8/41                  |           |   |  |                              |        |                                     |        |                                       |        |                    |        |   |        |              |        |
| 9 Clip plate  | → 8/44                  |           |   |  |                              |        |                                     |        |                                       |        |                    |        |   |        |              |        |
| PKZ2/ZM-1<br>026605   |                         |           | Overload release, adjustable<br>$I_r = 0.6 - 1.0 \times I_u$                                    |  |                              |        |                                     |        |                                       |        |                    |        |   |        |              |        |
| PKZ2/ZM-1,6<br>028978   |                         |           | Short-circuit release, adjustable<br>$I_m = 8.5 - 14 \times I_u$ factory set to $12 \times I_u$ |  |                              |        |                                     |        |                                       |        |                    |        |   |        |              |        |
| PKZ2/ZM-2,4<br>031351   |                         |           | World market devices to IEC $\Delta$ UL/CSA   |  |                              |        |                                     |        |                                       |        |                    |        |   |        |              |        |
| PKZ2/ZM-4<br>033724   |                         |           |   |  |                              |        |                                     |        |                                       |        |                    |        |   |        |              |        |
| PKZ2/ZM-6<br>036097   |                         |           |   |  |                              |        |                                     |        |                                       |        |                    |        |   |        |              |        |
| PKZ2/ZM-10<br>038470  |                         |           |   |  |                              |        |                                     |        |                                       |        |                    |        |   |        |              |        |
| PKZ2/ZM-16<br>040843  |                         |           |   |  |                              |        |                                     |        |                                       |        |                    |        |   |        |              |        |
| PKZ2/ZM-25<br>043216  |                         |           |   |  |                              |        |                                     |        |                                       |        |                    |        |   |        |              |        |
| PKZ2/ZM-32<br>045589  |                         |           |   |  |                              |        |                                     |        |                                       |        |                    |        |   |        |              |        |
| PKZ2/ZM-40<br>047962  |                         |           |   |  |                              |        |                                     |        |                                       |        |                    |        |   |        |              |        |
| PKZ2/ZM-10-8<br>050335  |                         | 1 off     | Overload release, adjustable<br>$I_r = 0.6 - 1.0 \times I_u$                                    |  |                              |        |                                     |        |                                       |        |                    |        |   |        |              |        |
| PKZ2/ZM-16-8<br>052708  |                         |           | Short-circuit release, adjustable<br>$I_m = 5.0 - 8.5 \times I_u$ factory set to $5 \times I_u$ |  |                              |        |                                     |        |                                       |        |                    |        |   |        |              |        |
| PKZ2/ZM-25-8<br>055081  |                         |           |   |  |                              |        |                                     |        |                                       |        |                    |        |   |        |              |        |
| PKZ2/ZM-32-8<br>057454  |                         |           |   |  |                              |        |                                     |        |                                       |        |                    |        |   |        |              |        |
| PKZ2/ZM-40-8<br>059827  |                         |           |   |  |                              |        |                                     |        |                                       |        |                    |        |   |        |              |        |

PKZ2 motor-protective circuit-breaker

PKZ2 motor-protective circuit-breaker



PKZ2/ZM

Moeller HPL0211-2007/2008

http://catalog.moeller.net

| Max. motor rating |       |       |       |       | Rated uninterrupted current | Setting range     |                        |
|-------------------|-------|-------|-------|-------|-----------------------------|-------------------|------------------------|
| AC-3              |       |       |       |       |                             | Overload releases | Short-circuit releases |
| 220 V             | 380 V | 440 V | 500 V | 660 V | $I_r$                       | $I_m$             | A                      |
| 230 V             | 400 V |       |       | 690 V |                             |                   |                        |
| 240 V             | 415 V |       |       |       |                             |                   |                        |
| $P$               | $P$   | $P$   | $P$   | $P$   | $I_u$                       | A                 | A                      |
| kW                | kW    | kW    | kW    | kW    |                             |                   |                        |

Compact starters, Type 1" coordination

|      |      |      |      |      |     |           |           |
|------|------|------|------|------|-----|-----------|-----------|
| 0.12 | 0.25 | 0.25 | 0.37 | 0.55 | 1   | 0.6...1   | 8...14    |
| 0.25 | 0.55 | 0.55 | 0.75 | 1.1  | 1.6 | 1...1.6   | 14...22   |
| 0.37 | 0.75 | 1.1  | 1.1  | 1.5  | 2.4 | 1.6...2.4 | 20...35   |
| 0.75 | 1.5  | 1.5  | 2.2  | 3    | 4   | 2.4...4   | 35...55   |
| 1.1  | 2.2  | 3    | 3    | 4    | 6   | 4...6     | 50...80   |
| 2.2  | 4    | 4    | 5.5  | 7.5  | 10  | 6...10    | 80...140  |
| 4    | 7.5  | 9    | 9    | 12.5 | 16  | 10...16   | 130...220 |
| 5.5  | 12.5 | 12.5 | 15   | 22   | 25  | 16...25   | 200...350 |
| 7.5  | 15   | 17.5 | 22   | 22   | 32  | 24...32   | 275...425 |
| 11   | 18.5 | 22   | 24   | 30   | 36  | 32...40   | 350...500 |

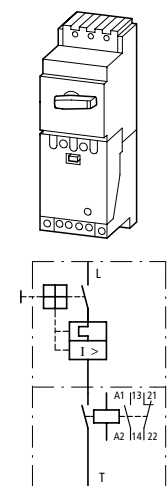

High-capacity compact starters, Type 2" coordination

|      |      |      |      |      |     |           |           |
|------|------|------|------|------|-----|-----------|-----------|
| 0.12 | 0.25 | 0.25 | 0.37 | 0.55 | 1   | 0.6...1   | 8...14    |
| 0.25 | 0.55 | 0.55 | 0.75 | 1.1  | 1.6 | 1...1.6   | 14...22   |
| 0.37 | 0.75 | 1.1  | 1.1  | 1.5  | 2.4 | 1.6...2.4 | 20...35   |
| 0.75 | 1.5  | 1.5  | 2.2  | 3    | 4   | 2.4...4   | 35...55   |
| 1.1  | 2.2  | 3    | 3    | 4    | 6   | 4...6     | 50...80   |
| 2.2  | 4    | 4    | 5.5  | 7.5  | 10  | 6...10    | 80...140  |
| 4    | 7.5  | 9    | 9    | 12.5 | 16  | 10...16   | 130...220 |
| 5.5  | 12.5 | 12.5 | 15   | 22   | 25  | 16...25   | 200...350 |
| 7.5  | 15   | 17.5 | 22   | 22   | 32  | 24...32   | 275...425 |
| 11   | 18.5 | 22   | 24   | 30   | 36  | 32...40   | 350...500 |

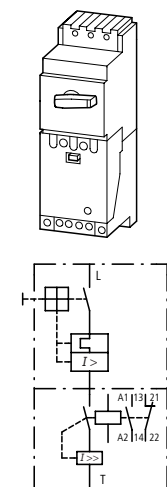

http://catalog.moeller.net

Moeller HPL0211-2007/2008

PKZ2/ZM

| Part no.<br>Article no. | Price<br>see price<br>list | Std. pack | Notes | Notes |
|-------------------------|----------------------------|-----------|-------|-------|
|-------------------------|----------------------------|-----------|-------|-------|

|  |
|--|
| PKZ2/ZM-1/SE1A/11(230V50HZ,240V60 063364 |
| PKZ2/ZM-1,6/SE1A/11(230V50HZ,240V 063372 |
| PKZ2/ZM-2,4/SE1A/11(230V50HZ,240V 063382 |
| PKZ2/ZM-4/SE1A/11(230V50HZ,240V60 063392 |
| PKZ2/ZM-6/SE1A/11(230V50HZ,240V60 063402 |
| PKZ2/ZM-10/SE1A/11(230V50HZ,240V6 063412 |
| PKZ2/ZM-16/SE1A/11(230V50HZ,240V6 063422 |
| PKZ2/ZM-25/SE1A/11(230V50HZ,240V6 063432 |
| PKZ2/ZM-32/SE1A/11(230V50HZ,240V6 063442 |
| PKZ2/ZM-40/SE1A/11(230V50HZ,240V6 063452 |

|   |
|---|
| PKZ2/ZM-1/S(230V50HZ,240V60HZ) 063472   |
| PKZ2/ZM-1,6/S(230V50HZ,240V60HZ) 063482 |
| PKZ2/ZM-2,4/S(230V50HZ,240V60HZ) 063492 |
| PKZ2/ZM-4/S(230V50HZ,240V60HZ) 063502   |
| PKZ2/ZM-6/S(230V50HZ,240V60HZ) 063512   |
| PKZ2/ZM-10/S(230V50HZ,240V60HZ) 063522  |
| PKZ2/ZM-16/S(230V50HZ,240V60HZ) 063532  |
| PKZ2/ZM-25/S(230V50HZ,240V60HZ) 063542  |
| PKZ2/ZM-32/S(230V50HZ,240V60HZ) 063552  |
| PKZ2/ZM-40/S(230V50HZ,240V60HZ) 063562  |

1 off  
1 M/1 B auxiliary contact built into the contact module

1 off  
Rated short-circuit current  $I_q = 100 \text{ kA/400 V}$   
High-capacity contact module has built-in auxiliary contacts: 1 M/1 B

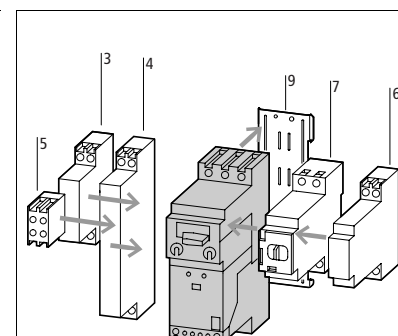

| Accessories                           | Page   |
|---------------------------------------|--------|
| 3 Standard auxiliary contact          | → 8/35 |
| 4 Standard auxiliary contact          | → 8/35 |
| 5 Trip-indicating auxiliary contact   | → 8/35 |
| 6 Shunt release, undervoltage release | → 8/37 |
| 7 Remote operators                    | → 8/39 |
| 9 Clip plate                          | → 8/44 |
| Other accessories                     | → 8/33 |
| Further actuating voltages            | → 8/45 |
| Manual                                | → 8/44 |

Single-phasing sensitivity to IEC/EN 60947-4-1, VDE 0660 Part 102  
Supplied fitted to C-PKZ2 clip plate, can be snap fitted to one or two IEC/EN 60715 top-hat rails, height 15 mm

Overload release, adjustable  $I_r = 0.6 - 1.0 \times I_u$   
Adjustable short-circuit release  $I_m = 8.5 - 14 \times I_u$  set ex-works to  $12 \times I_u$

PTB 02 ATEX 3152  
Observe manual.

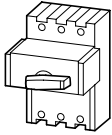
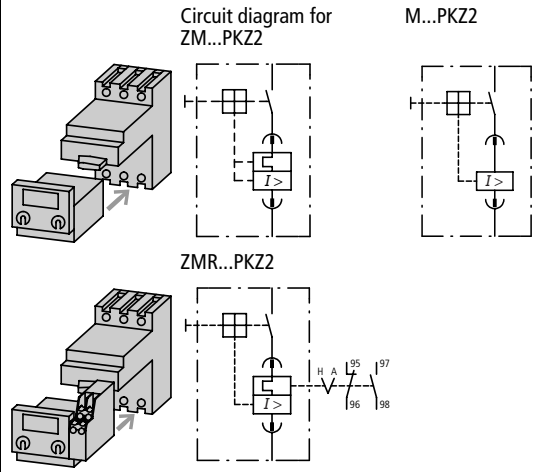
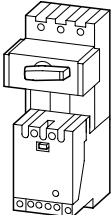
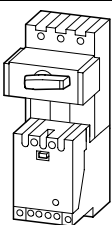

|   | Rated uninterupted current<br>$I_u$<br>A | Part no.<br>Article no.                 | Price<br>see price list<br>RG | Std. pack |  |
|---|--|---|-------------------------------|-----------|--|
| <b>Basic unit, 3-pole</b>   |  |   |                               |           |  |
|    | 40                                       | <b>PKZ2</b><br>026606                   |                               | 1 off     |  <p><b>Circuit diagram for ZM...PKZ2</b></p> <p><b>M...PKZ2</b></p> <p><b>ZMR...PKZ2</b></p> <p>Adjustable:<br/>                     H <math>\Delta</math> manual position or<br/>                     A <math>\Delta</math> automatic position<br/>                     For EEx e applications the 95/96 N/C contact must always be used to de-energize the (high-capacity) contact module or contactor.<br/>                     Motor-protective trip blocks ZMR-...PKZ2 cannot be combined with U/A voltage releases and RE/RS remote operators.</p> <p>Further actuating voltages <math>\rightarrow</math> 8/45<br/>                     Manual <math>\rightarrow</math> 8/44</p> |
| <br>PKZ2 basic unit with S-PKZ2 high-capacity contact module fitted (1 M, 1 B) Supplied on C-PKZ2 clip plate. Cannot be combined with Z...-0.6-PKZ2. | 40                                       | <b>PKZ2/S(230V50HZ)</b><br>063572       |                               |           |  |
| <br>PKZ2 basic unit with SE1A/11-PKZ2 contact module fitted (1 M, 1 B) Supplied on C-PKZ2 clip plate. Cannot be combined with Z...-0.6-PKZ2.         | 40                                       | <b>PKZ2/SE1A/11(230V50HZ)</b><br>082142 |                               |           |  |

Max. motor rating

AC-3

|       |       |       |       |       |
|-------|-------|-------|-------|-------|
| 220 V | 380 V | 440 V | 500 V | 660 V |
| 230 V | 400 V |       |       | 690 V |
| 240 V | 415 V |       |       |       |

|    |    |    |    |    |       |       |          |   |
|----|----|----|----|----|-------|-------|----------|---|
| P  | P  | P  | P  | P  | $I_u$ | $I_r$ | $I_{rm}$ |  |
| kW | kW | kW | kW | kW | A     | A     | A        |   |

Rated uninterupted current

Setting range

|                   |                        |
|-------------------|------------------------|
| Overload releases | Short-circuit releases |
|-------------------|------------------------|

Part no.  
Article no.

Price  
see price list

Std. pack

**Motor-protective trip blocks, 3-pole**

With overload release

|   | 0.09 | 0.12 | 0.18 | 0.25 | 0.25 | 0.6 | 0.4...0.6 | 5...8     | Part no.<br>Article no.      | Price<br>see price list | Std. pack |  |
|---|------|------|------|------|------|-----|-----------|-----------|------------------------------|-------------------------|-----------|--|
|  |      |      |      |      |      |     |           |           | <b>ZM-0.6-PKZ2</b><br>024232 |                         | 1 off     | Single-phasing sensitivity to IEC/EN 60947-4-1<br><br>Suitable for the protection of EEx e motors<br>PTB Certificate No.: 3.53-388.299<br><br>Extension to ATEX applied for<br><br>Overload releases, adjustable<br>$I_r = 0.6 - 1.0 \times I_u$<br><br>Adjustable short-circuit release<br>$I_{rm} = 8.5 - 14 \times I_u$<br>Factory set to $12 \times I_u$ |
|   | 0.12 | 0.25 | 0.25 | 0.37 | 0.55 | 1   | 0.6...1   | 8...14    | <b>ZM-1-PKZ2</b><br>028979   |                         |           |  |
|   | 0.25 | 0.55 | 0.55 | 0.75 | 1.1  | 1.6 | 1...1.6   | 14...22   | <b>ZM-1,6-PKZ2</b><br>031352 |                         |           |  |
|   | 0.37 | 0.75 | 1.1  | 1.1  | 1.5  | 2.4 | 1.6...2.4 | 20...35   | <b>ZM-2,4-PKZ2</b><br>033725 |                         |           |  |
|   | 0.75 | 1.5  | 1.5  | 2.2  | 3    | 4   | 2.4...4   | 35...55   | <b>ZM-4-PKZ2</b><br>036098   |                         |           |  |
|   | 1.1  | 2.2  | 3    | 3    | 4    | 6   | 4...6     | 50...80   | <b>ZM-6-PKZ2</b><br>038471   |                         |           |  |
|   | 2.2  | 4    | 4    | 5.5  | 7.5  | 10  | 6...10    | 80...140  | <b>ZM-10-PKZ2</b><br>040844  |                         |           |  |
|   | 4    | 7.5  | 9    | 9    | 12.5 | 16  | 10...16   | 130...220 | <b>ZM-16-PKZ2</b><br>043217  |                         |           |  |
|   | 5.5  | 12.5 | 12.5 | 15   | 22   | 25  | 16...25   | 200...350 | <b>ZM-25-PKZ2</b><br>045590  |                         |           |  |
|   | 7.5  | 15   | 17.5 | 22   | 22   | 32  | 24...32   | 275...425 | <b>ZM-32-PKZ2</b><br>047963  |                         |           |  |
|   | 11   | 20   | 22   | 24   | 30   | 40  | 32...40   | 350...500 | <b>ZM-40-PKZ2</b><br>050336  |                         |           |  |



| 220 – 240 V |          |          |          |          | Rated<br>uninter-<br>rupted<br>current | Setting range        |                           | Part no.<br>Article no.   | Price<br>see price<br>list | Std.<br>pack |
|-------------|----------|----------|----------|----------|--|----------------------|---------------------------|---|----------------------------|--------------|
| AC-3        |          |          |          |          |  | Overload<br>releases | Short-circuit<br>releases |   |                            |              |
| 220 V       | 380 V    | 440 V    | 500 V    | 660 V    |  |                      |                           |   |                            |              |
| 230 V       | 400 V    |          |          | 690 V    |  |                      |                           |   |                            |              |
| 240 V       | 415 V    |          |          |          |  |                      |                           |   |                            |              |
| <i>P</i>    | <i>P</i> | <i>P</i> | <i>P</i> | <i>P</i> | $I_u$                                  | $I_t$                | $I_{rm}$                  |   |                            |              |
| kW          | kW       | kW       | kW       | kW       | A                                      | A                    | A                         |  |                            |              |

**Motor-protective trip blocks, 3-pole**

With overload relay function, with Hand/Auto position

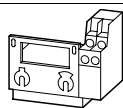

|      |      |      |      |      |     |           |           |                        |
|------|------|------|------|------|-----|-----------|-----------|------------------------|
| 0.09 | 0.12 | 0.18 | 0.25 | 0.25 | 0.6 | 0.4...0.6 | 5...8     | ZMR-0,6-PKZ2<br>033943 |
| 0.12 | 0.25 | 0.25 | 0.37 | 0.55 | 1   | 0.6...1   | 8...14    | ZMR-1-PKZ2<br>033950   |
| 0.25 | 0.55 | 0.55 | 0.75 | 1.1  | 1.6 | 1...1.6   | 14...22   | ZMR-1,6-PKZ2<br>033952 |
| 0.37 | 0.75 | 1.1  | 1.1  | 1.5  | 2.4 | 1.6...2.4 | 20...35   | ZMR-2,4-PKZ2<br>033955 |
| 0.75 | 1.5  | 1.5  | 2.2  | 3    | 4   | 2.4...4   | 35...55   | ZMR-4-PKZ2<br>033957   |
| 1.1  | 2.2  | 3    | 3    | 4    | 6   | 4...6     | 50...80   | ZMR-6-PKZ2<br>033966   |
| 2.2  | 4    | 4    | 5.5  | 7.5  | 10  | 6...10    | 80...140  | ZMR-10-PKZ2<br>033967  |
| 4    | 7.5  | 9    | 9    | 12.5 | 16  | 10...16   | 130...220 | ZMR-16-PKZ2<br>033968  |
| 5.5  | 12.5 | 12.5 | 15   | 22   | 25  | 16...25   | 200...350 | ZMR-25-PKZ2<br>033969  |
| 7.5  | 15   | 17.5 | 22   | 22   | 32  | 24...32   | 275...425 | ZMR-32-PKZ2<br>033973  |
| 11   | 20   | 22   | 24   | 30   | 40  | 32...40   | 350...500 | ZMR-40-PKZ2<br>033975  |

Without overload release



|   |   |   |   |   |     |      |           |                      |
|---|---|---|---|---|-----|------|-----------|----------------------|
| - | - | - | - | - | 0.6 | -... | 5...8     | M-0,6-PKZ2<br>004537 |
| - | - | - | - | - | 1   | -... | 8...14    | M-1-PKZ2<br>004538   |
| - | - | - | - | - | 1.6 | -... | 14...22   | M-1,6-PKZ2<br>004539 |
| - | - | - | - | - | 2.4 | -... | 20...35   | M-2,4-PKZ2<br>004540 |
| - | - | - | - | - | 4   | -... | 35...55   | M-4-PKZ2<br>004541   |
| - | - | - | - | - | 6   | -... | 50...80   | M-6-PKZ2<br>004542   |
| - | - | - | - | - | 10  | -... | 80...140  | M-10-PKZ2<br>004543  |
| - | - | - | - | - | 16  | -... | 130...220 | M-16-PKZ2<br>004544  |
| - | - | - | - | - | 25  | -... | 200...350 | M-25-PKZ2<br>004545  |
| - | - | - | - | - | 32  | -... | 275...425 | M-32-PKZ2<br>004546  |
| - | - | - | - | - | 40  | -... | 350...500 | M-40-PKZ2<br>004547  |

1 off

Phase-failure sensitivity and overload/short-circuit release setting options and PTB, see above.  
When using motor-protective trip blocks with an overload relay function, the motor-protective circuit-breaker does not trip in the event of an overload. The overload indication is produced by means of two auxiliary contacts. Different potentials may be applied to the two auxiliary contacts.

1 off

Adjustable short-circuit release  
 $I_{rm} = 8.5 - 14 \times I_u$   
Factory set to  $12 \times I_u$





**Notes**

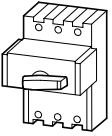
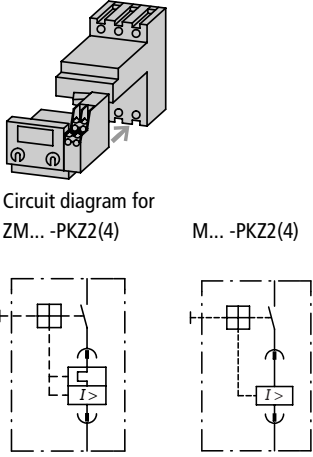
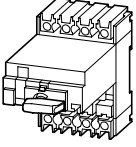

When using the M-...-PKZ2 as short-circuit protection for motors with heavy starting duty, the rated operational current  $I_e$  must be up-rated when engineering by the following factors:

| CLASS | Factor |
|-------|--------|
| 5     | 1.0    |
| 10    | 1.0    |
| 15    | 1.22   |
| 20    | 1.41   |
| 25    | 1.58   |
| 30    | 1.73   |
| 35    | 1.89   |
| 40    | 2.0    |

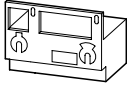
|   | Rated uninterrupted current<br>$I_u$ | Part no.<br>Article no. | Price<br>see price list | Std. pack |   |
|---|--------------------------------------|-------------------------|-------------------------|-----------|---|
| <b>Basic unit, 3-pole</b>   |                                      |                         |                         |           |   |
|  | 40                                   | <b>PKZ2</b><br>026606   |                         | 1 off     |  <p>Circuit diagram for<br/>ZM... -PKZ2(4)      M... -PKZ2(4)</p> |
| <b>Basic unit, 4-pole</b>   |                                      |                         |                         |           |   |
|  | 40                                   | <b>PKZ24</b><br>004521  |                         | 1 off     |   |

|   | Rated uninterrupted current<br>$I_u$ | Setting range   |   | Part no.<br>Article no.        | Price<br>see price list<br>RG | Std. pack  |
|---|--------------------------------------|---|---|--------------------------------|-------------------------------|--|
|   | A                                    | Overload releases<br>$I_r$  | Short-circuit releases<br>$I_{rm}$  |                                |                               |  |
|   |                                      | A   | A   |                                |                               |  |
|   |                                      |  |  |                                |                               |  |
| <b>Trip block for distribution circuit protection</b>                               |                                      |   |   |                                |                               |  |
| <b>3-pole</b>   |                                      |   |   |                                |                               |  |
| <b>With overload release</b>  |                                      |   |   |                                |                               |  |
|  | 10                                   | 6...10  | 50...80   | <b>ZM-10-8-PKZ2</b><br>062201  |                               | 1 off<br><br>Overload releases, adjustable<br>$I_r = 0.6 - 1.0 \times I_u$<br><br>Adjustable short-circuit release<br>$I_{rm} = 5 - 8.5 \times I_u$ factory set to $5 \times I_u$  |
|   | 16                                   | 10...16   | 80...140  | <b>ZM-16-8-PKZ2</b><br>059828  |                               |  |
|   | 25                                   | 16...25   | 130...210   | <b>ZM-25-8-PKZ2</b><br>057455  |                               |  |
|   | 32                                   | 24...32   | 160...280   | <b>ZM-32-8-PKZ2</b><br>055082  |                               |  |
|   | 40                                   | 32...40   | 200...350   | <b>ZM-40-8-PKZ2</b><br>052709  |                               |  |
| <b>4-pole</b>   |                                      |   |   |                                |                               |  |
| <b>With overload releases in all 4 poles</b>  |                                      |   |   |                                |                               |  |
|  | 10                                   | 6...10  | 50...80   | <b>ZM-10-8-PKZ24</b><br>004526 |                               | 1 off<br><br>Overload releases, adjustable<br>$I_r = 0.6 - 1.0 \times I_u$<br><br>Adjustable short-circuit release<br>$I_{rm} = 5 - 8.5 \times I_u$ factory set to $5 \times I_u$<br><br>Circuit-breakers PKZ24/ZM-...-8 protect in all 4-poles. |
|   | 16                                   | 10...16   | 80...140  | <b>ZM-16-8-PKZ24</b><br>004525 |                               |  |
|   | 25                                   | 16...25   | 130...210   | <b>ZM-25-8-PKZ24</b><br>004524 |                               |  |
|   | 32                                   | 24...32   | 160...280   | <b>ZM-32-8-PKZ24</b><br>004523 |                               |  |
|   | 40                                   | 32...40   | 200...350   | <b>ZM-40-8-PKZ24</b><br>004522 |                               |  |

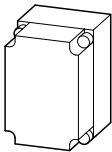
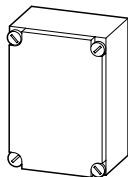
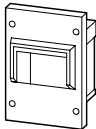
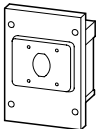
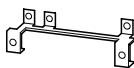

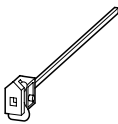
|   |  | Colour             | Part no.<br>Article no.       | Price<br>see price list | Std. pack | Notes  |
|---|--|--------------------|-------------------------------|-------------------------|-----------|--|
| <b>Insulated enclosures for surface mounting</b>  |  |                    |                               |                         |           |  |
| For motor-protective circuit-breakers, 3- or 4-pole circuit-breakers                              |  |                    |                               |                         |           |  |
|                  | Degree of protection IP40 Cover with aperture dimensioned to accommodate front of breaker, comes with blanking strip |                    | <b>CI19EA-PKZ2</b><br>026234  |                         | 1 off     | Built-in IEC/EN 60715 top-hat rail, separate terminals for PE(N)- and N                              |
|   | Degree of protection IP54 For mounting of (R)H-PKZ2 door coupling handle   |                    | <b>CI19EB-PKZ2</b><br>028607  |                         |           | incl. cable entry 2 × PG 16/21/29  |
|   | Degree of protection IP54 For mounting of (R)H-PKZ2 door coupling handle   |                    | <b>CI19ED-PKZ24</b><br>005145 |                         |           | L-PKZ0 indicator light can be fitted   |
| For 3-pole compact starters, high-capacity compact starters, combination circuit-breakers (Kombi) |  |                    |                               |                         |           |  |
|                  | Degree of protection IP40 Cover with aperture dimensioned to accommodate front of breaker, comes with blanking strip |                    | <b>CI23EA-PKZ2</b><br>087936  |                         | 1 off     | Complete with L3/5-CI23 mounting plate   |
|   | Degree of protection IP54 For mounting of (R)H-PKZ2 door coupling handle   |                    | <b>CI23EB-PKZ2</b><br>090309  |                         |           | Will accept compact starter or PKZ2/ZM.../S high-capacity compact starter without clip plate         |
| <b>Insulated enclosures for flush mounting</b>  |  |                    |                               |                         |           |  |
| For motor-protective circuit-breakers, 3- or 4-pole circuit-breakers                              |  |                    |                               |                         |           |  |
|                | Degree of protection IP41 Grey front plate with retaining frame Integral PE(N) terminal                              |                    | <b>E-PKZ2</b><br>003218       |                         | 1 off     | For mounting in side plate or door. Vertical mounting position. L-PKZ0 indicator light can be fitted |
|                | Degree of protection IP54 (R)H-PKZ2 door coupling handle also required as standard                                   |                    | <b>E54-PKZ2</b><br>033939     |                         |           |  |
| <b>Neutral terminal</b>   |  |                    |                               |                         |           |  |
| For connection of a 5th conductor   |  |                    |                               |                         |           |  |
|                |  | E-PKZ2<br>E54-PKZ2 | <b>N-PKZ2</b><br>003219       |                         | 1 off     |  |
| <b>Door coupling handles</b>  |  |                    |                               |                         |           |  |
| Degree of protection IP65   |  |                    |                               |                         |           |  |
|                | For use as main switch to IEC/EN 60204   | Black              | <b>PKZ2-XH</b><br>106127      |                         | 1 off     | Lockable in 0 or I position Suitable for 3 padlocks with 4 – 8 mm hasp thickness                     |
|   | For use in MCC distribution boards with PKZ2 turned through 90°. For use as main switch according to EN 60204        | Black              | <b>PKZ2-XH-MCC</b><br>106130  |                         |           |  |
|   | For use as a main switch with Emergency-Stop function, to EN 60204   | Red-yellow         | <b>PKZ2-XRH</b><br>106128     |                         |           |  |
| <b>Plug-fit extension shaft for door coupling handle</b>  |  |                    |                               |                         |           |  |
| Can be extended as required for mounting depths from 171 - 300 mm                                 |  |                    |                               |                         |           |  |
|                |  |                    | <b>PKZ2-XAH</b><br>106129     |                         | 1 off     |  |



NHI...-PKZ2

Moeller HPL0211-2007/2008

http://catalog.moeller.net

Contacts  
N/O = Normally open  
N/C = Normally closed

Contact diagram

Contact sequence

Standard auxiliary contacts

For motor-protective circuit-breakers, circuit-breakers, and (high-capacity) compact starters

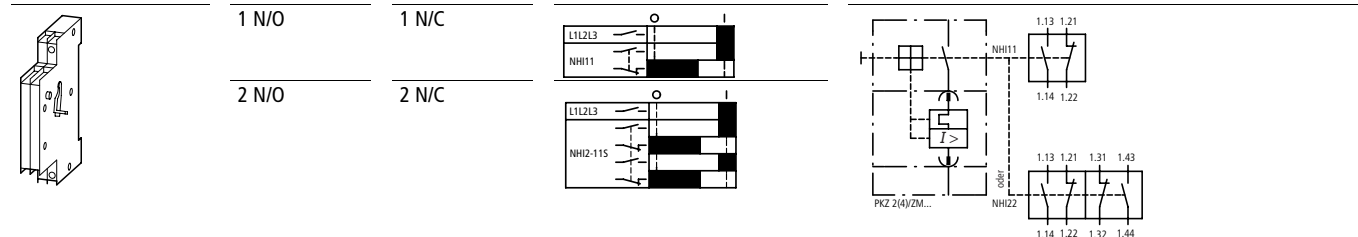

For (high-capacity) compact starters

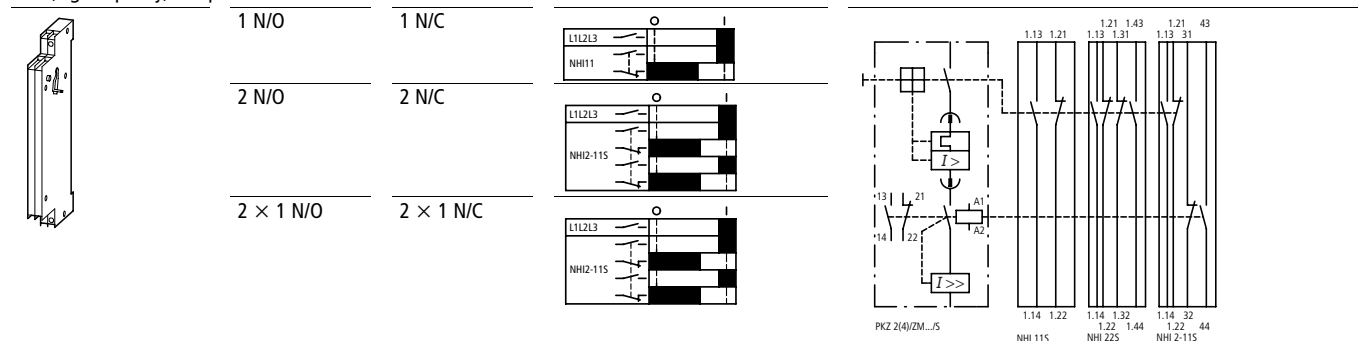

Trip-indicating auxiliary contacts with short-circuit indicator

For motor-protective circuit-breakers, circuit-breakers, and (high-capacity) compact starters

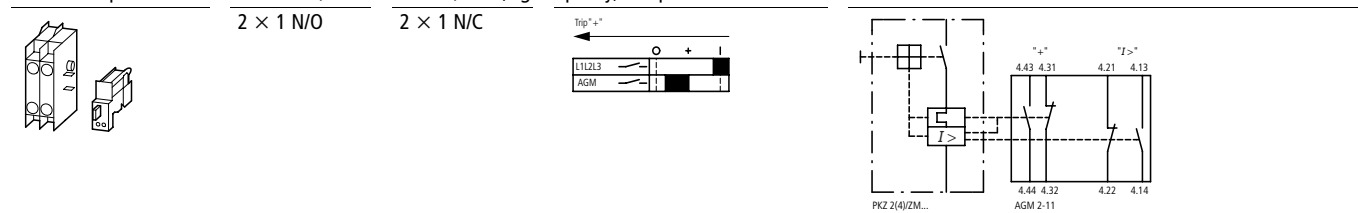

Short-circuit indicators

For motor-protective circuit-breakers, circuit-breakers, and (high-capacity) compact starters

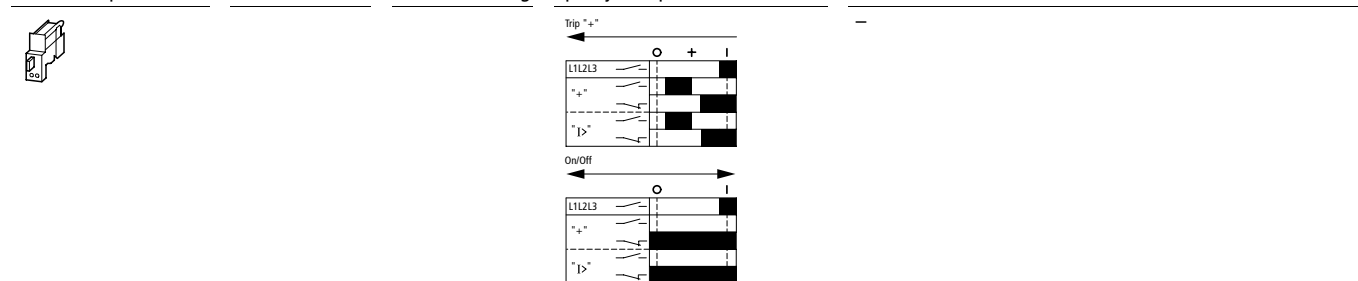

Current limiters

To increase the switching capacity of non-inherently short-circuit-proof motor-protective circuit-breakers to 100 kA/500 V

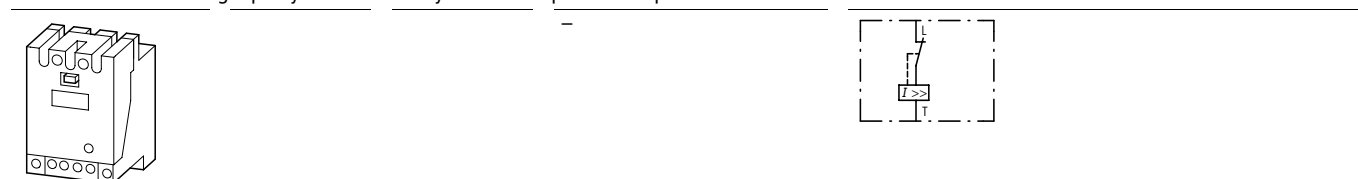

http://catalog.moeller.net

Moeller HPL0211-2007/2008

NHI...-PKZ2

| Part no.<br>Order number for separate orders | Price<br>see price list | Std. pack | Notes   |
|--|-------------------------|-----------|---|
| NHI11-PKZ2 090677                            |                         | 1 off     | Can be fitted to circuit-breaker and (high-capacity) compact starter.   |
| NHI22-PKZ2 097796                            |                         | 1 off     | Can be combined with AGM trip-indicating auxiliary contacts   |
| NHI115-PKZ2 007623                           |                         | 1 off     | Can be fitted to the starter combination<br>Can be combined with AGM trip-indicating auxiliary contacts,  |
| NHI225-PKZ2 000504                           |                         |           |   |
| NHI2-115-PKZ2 009996                         |                         |           |   |
| AGM2-11-PKZ2 017115                          |                         | 1 off     | Differential remote indication:<br>a) General trip indication "+", overload,<br>b) Short-circuit trip<br><br>Can be fitted to circuit-breaker and (high-capacity) compact starter.<br><br>Can be combined with NHI... or NHI...S standard auxiliary contacts    |
| K-AGM-PKZ2 021861                            |                         | 5 off     | Local short-circuit indication by resettable indicator.<br><br>Can be used in circuit-breakers and (high-capacity) compact starters   |
| CL-PKZ2 076439                               |                         | 1 off     | Max. rated operational voltage $U_e = 690$ V<br>Rated uninterrupted current $I_u = 40$ A<br>Can be retrofitted to circuit-breaker or can be fitted individually with EZ plinth<br>Can be used as individual contactor<br>C-PKZ2 clip plate required as standard |

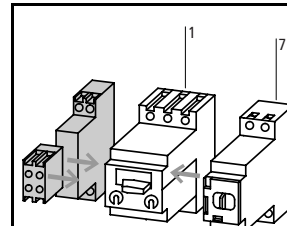

| Accessories  | Page   |
|--|--------|
| 1 Motor-protective circuit-breaker, circuit-breakers | → 8/27 |
| 7 Remote operators                                   | → 8/39 |
| Additional accessories                               | → 8/33 |

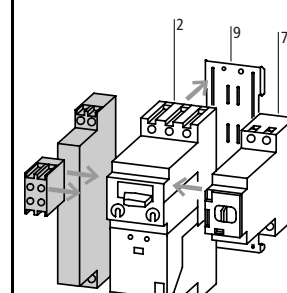

| Accessories                       | Page   |
|-----------------------------------|--------|
| 2 (High-capacity) compact starter | → 8/29 |
| 7 Remote operators                | → 8/39 |
| 9 Clip plate                      | → 8/44 |
| Additional accessories            | → 8/33 |

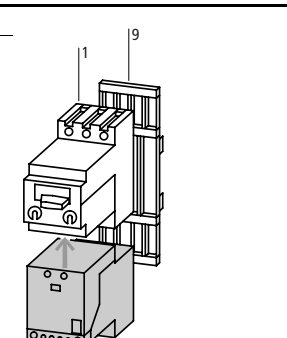

| Accessories   | Page   |
|---|--------|
| 1 Motor-protective circuit-breaker, circuit-breaker | → 8/27 |
| 9 clip plates                                       | → 8/44 |
| Additional accessories                              | → 8/33 |

PKZ2 motor-protective circuit-breaker

PKZ2 motor-protective circuit-breaker



Contact sequence    Contact diagram    Actuating voltage  
Voltage and frequency combination possible with one coil in the voltage release.

**Shunt releases**

For AC and DC

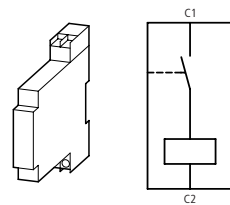

|             |             |             |
|-------------|-------------|-------------|
| 24 V DC     | 48 V DC     | 60 V DC     |
| 24 V 50Hz   | 48 V 50Hz   |             |
| 24 V 60 Hz  | 48 V 60Hz   |             |
| 110 V DC    | 125 V DC    | 250 V DC    |
| 110 V 50Hz  | 127 V 50Hz  | 220 V 50Hz  |
| 230 V 50Hz  | 240 V 50Hz  |             |
| 110 V 60Hz  | 120 V 60 Hz | 208 V 60 Hz |
| 220 V 60 Hz | 240 V 60Hz  |             |
| 380 V 50Hz  | 400 V 50Hz  | 415 V 50Hz  |
| 440 V 50Hz  | 500 V 50Hz  |             |
| 480 V 60 Hz | 600 V 60 Hz |             |

**Undervoltage releases, non-delayed**

Without auxiliary contact

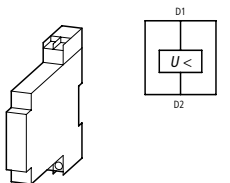

For AC  
For DC

With auxiliary contact  
For AC

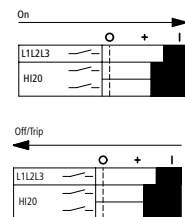
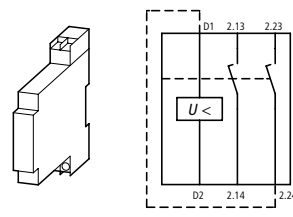

**Undervoltage release off-delayed, delay time 200 ms**

With auxiliary contact  
For AC

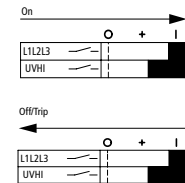
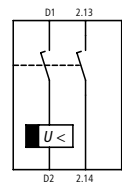

Type  
Order number for separate orders    Price  
see price list  
RG

Notes

**A-PKZ2-A**  
063967

Can be fitted to motor-protective circuit-breaker, circuit-breaker, (high-capacity) compact starter  
Can be combined with remote operator.

**A-PKZ2-B**  
063964

**A-PKZ2-C**  
063930

**U-PKZ2(230V50HZ)**  
065766

Can be fitted to motor-protective circuit-breaker, circuit-breaker, (high-capacity) compact starter

**U-PKZ2(24VDC)**  
014463

Can be combined with remote operator.

When combined with circuit-breaker, can be used as Emergency-Stop device to IEC/EN 60204.

**U-HI20-PKZ2(230V50HZ)**  
065768

Can be fitted to motor-protective circuit-breaker, circuit-breaker, (high-capacity) compact starter

Can be combined with remote operator.  
Two integral early-make contacts.  
When combined with circuit-breaker, can be used as Emergency-Stop device to IEC/EN 60204.  
When the circuit-breaker is in the tripped position "+", the auxiliary contacts are closed.  
The undervoltage release can be energized early by means of an additional link (see circuit diagram). This function must not be used in conjunction with RE/RS-PKZ2 (remote operators).

**UVHI-PKZ2(230V50HZ)**  
065770

Can be fitted to motor-protective circuit-breaker, circuit-breaker, (high-capacity) compact starter

Can be combined with remote operator.  
Two integral early-make contacts.  
Voltage dips  $\leq 200$  ms do not result in disconnection, Contact time on energization: 200 ms.  
When the circuit-breaker is in the tripped position, the auxiliary contacts are closed.

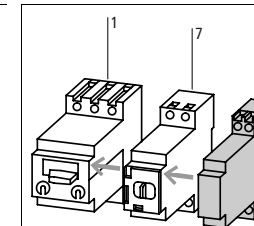

| Accessories  | Page   |
|--|--------|
| 1 Motor-protective circuit-breaker, circuit-breakers | → 8/27 |
| 7 Remote operators                                   | → 8/39 |
| Additional accessories                               | → 8/33 |

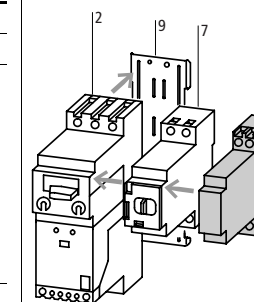

| Accessories                       | Page   |
|-----------------------------------|--------|
| 2 (High-capacity) compact starter | → 8/29 |
| 7 Remote operators                | → 8/39 |
| 9 Clip plate                      | → 8/44 |
| Additional accessories            | → 8/33 |
| Further actuating voltages        | → 8/45 |



Contact sequence

Circuit diagram for pulsed operation

OFF and RESET separate

OFF equals RESET

RE-PKZ2 remote operator

Actuation via auxiliary contact

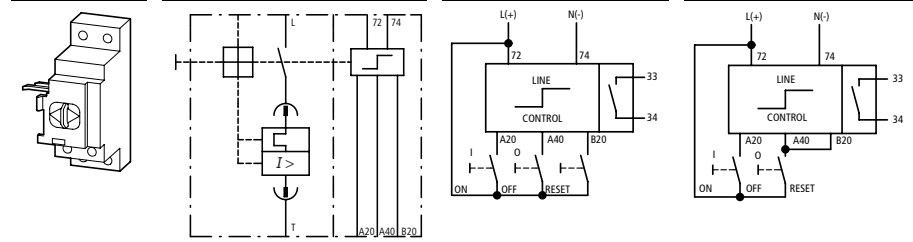

Power and control sections have the same potential. Can be actuated by a single pulse ( $\cong 2 \text{ VA/W}$ , 15 ms) or by maintained contact. When activated, the power section is energized directly from the mains supply (700 VA/W, 30 ms). Control section can be activated by: NHI, AGM, ETS4-VS3, EK..., PLC with isolated contacts without RC suppressor.

RS-PKZ2 remote operator

Actuation from PLC semi-conductor outputs

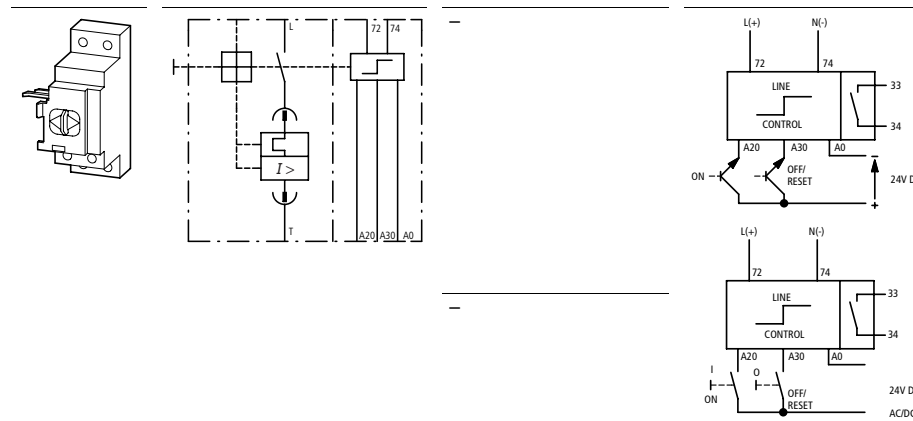

Power and control sections electrically isolated from one another. Control section always 24 V. Safe isolation between power and control section is assured. Can be actuated by a single pulse ( $\cong 2 \text{ VA/W}$ , 15 ms) or by maintained contact. The control section can be activated directly from the PLC electronic outputs (24 V DC). When activated, the power section is energized directly from the mains supply (700 VA/W, 30 ms).

| Part no.<br>Article no.               | Price<br>see price list | Std. pack | Notes   |
|---------------------------------------|-------------------------|-----------|---|
| RE-PKZ2(220-240V50/60HZ,DC)<br>063676 |                         | 1 off     | Can be fitted to circuit-breaker and (high-capacity) compact starter. Remote On/Off switching of circuit-breaker and trip reset to OFF.<br>Remote operator can be switched off locally and the thumb-grip locked using 6 mm padlock. Suitable for use with AC or DC. Can be combined with U, U-HI20, UVHI-PKZ2 voltage releases or A-PKZ2.  |
| RE-PKZ2(110-120V50/60HZ,DC)<br>063673 |                         | 1 off     |   |
| RE-PKZ2(24V50/60HZ,DC)<br>063670      |                         | 1 off     |   |
| RS-PKZ2(220-240V50/60HZ,DC)<br>063688 |                         | 1 off     | NHI standard auxiliary contact is always required in addition for combination of circuit-breaker and RE/RS-PKZ2 remote operator. Cannot be used in conjunction with (R)H-PKZ2 door-coupling handle.<br>Mounting is possible in On and Off switch positions. Internal electronic interlocking always makes "Off" a priority. A green background to the slide indicates the $\Delta$ "Hand" position with contacts (33/34) open. A red background to the slide indicates the $\Delta$ "Auto" position with contacts (33/34) closed. In the "Hand" position, remote switching is not possible. |
| RS-PKZ2(380-415V50/60HZ)<br>063689    |                         | 1 off     |   |
| RS-PKZ2(24V50/60HZ,DC)<br>063682      |                         | 1 off     |   |

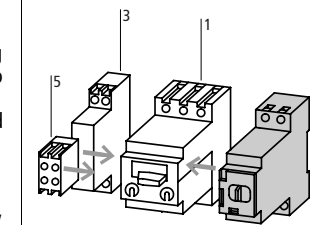

| Accessories  | Page   |
|--|--------|
| 1 Motor-protective circuit-breaker, circuit-breakers | → 8/27 |
| 3 Standard auxiliary contact                         | → 8/35 |
| 5 Trip-indicating auxiliary contact                  | → 8/35 |
| Additional accessories                               | → 8/33 |

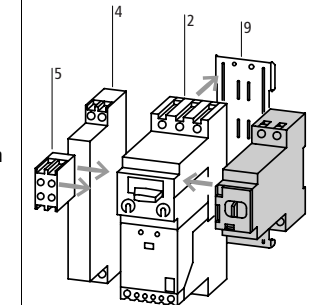

| Accessories                         | Page   |
|-------------------------------------|--------|
| 2 (high-capacity) compact starters  | → 8/29 |
| 4 Standard auxiliary contact        | → 8/35 |
| 5 Trip-indicating auxiliary contact | → 8/35 |
| 9 Clip plate                        | → 8/44 |

Minimum command time:

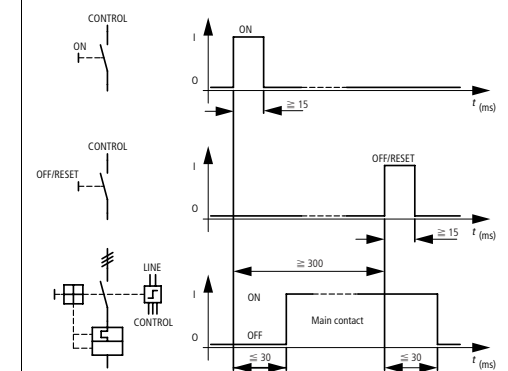

| Contact sequence | 220 – 240 V |       |       |       |       | Auxiliary contacts |                   | For use with |
|------------------|-------------|-------|-------|-------|-------|--------------------|-------------------|--------------|
|                  | AC-3        |       |       |       |       | N/O =<br>Normally  | N/C =<br>Normally |              |
|                  | 220 V       | 380 V | 440 V | 500 V | 660 V |                    |                   |              |
|                  | 230 V       | 400 V |       |       | 690 V |                    |                   |              |
|                  | 240 V       | 415 V |       |       |       |                    |                   |              |
|                  | P           | P     | P     | P     | P     |                    |                   |              |
|                  | kW          | kW    | kW    | kW    | kW    |                    |                   |              |

Contact module

|  |   |    |    |    |    |    |       |       |         |
|--|---|----|----|----|----|----|-------|-------|---------|
|   |  | 11 | 20 | 22 | 24 | 30 | 1 N/O | 1 N/C | PKZ2(4) |
|   |  | 11 | 20 | 22 | 24 | 30 | 2 M   | –     | PKZ2(4) |
|  |  | 11 | 20 | 22 | 24 | 30 | 1 M   | –     | PKZ2(4) |

High-capacity contact module with current limiting contacts

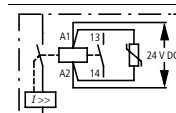
|   |   |    |    |    |    |    |       |       |         |
|---|---|----|----|----|----|----|-------|-------|---------|
|   |   | 11 | 20 | 22 | 24 | 30 | 1 N/O | 1 N/C | PKZ2(4) |
|  |  | 11 | 20 | 22 | 24 | 30 | 2 N/O | –     | PKZ2(4) |
|  |  | 11 | 20 | 22 | 24 | 30 | 1 N/O | –     | PKZ2(4) |

Suppressor circuit Varistor suppressor

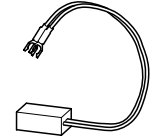
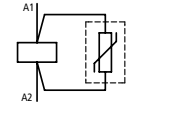
|   |   |                |   |   |   |   |   |   |                 |
|---|---|----------------|---|---|---|---|---|---|-----------------|
|  |  | 24 – 48 V AC   | – | – | – | – | – | – | S(E1A)-...-PKZ2 |
|   |   | 110 – 250 V AC | – | – | – | – | – | – |                 |
|   |   | 380 – 415 V AC | – | – | – | – | – | – |                 |

Bases for separate mounting

|   |  |   |   |   |   |   |   |   |                            |
|---|--|---|---|---|---|---|---|---|----------------------------|
|  |  | – | – | – | – | – | – | – | S(E1A)-...-PKZ2<br>CL-PKZ2 |
|---|--|---|---|---|---|---|---|---|----------------------------|

| Part no.<br>Article no.  | Price<br>see price<br>list | Std. pack | Notes  |
|--|----------------------------|-----------|--|
| SE1A/11-PKZ2(230V50HZ)<br>063711                                 |                            | 1 off     | Clip plate for snap fitting the combination to be ordered separately. Can be fitted to 3 or 4-pole circuit-breaker. When combined with a clip plate can be snap fitted to one IEC/EN 60715 top-hat rail with 15 mm height or two with 15 mm height.                                      |
| SE1A/20-PKZ2(230V50HZ)<br>063718                                 |                            |           | Can be mounted separately using base (see below), RC suppressor on request.  |
| SE1A-G-10-PKZ2(24VDC)<br>058856                                  |                            |           | DC version: The coil cannot be changed. The HI10-S-PKZ2 integral auxiliary contact is freely configurable. The auxiliary contact cannot be changed.<br>DC version with varistor suppressor present. High-capacity contact modules with serial no. 01 suitable for mounting with MV-PKZ2. |
| S-PKZ2(230V50HZ)<br>063696                                       |                            | 1 off     |  |
| S/HI20-S-PKZ2(230V50HZ)<br>063703                                |                            |           |  |
| S-G-PKZ2(24VDC)<br>070921  |                            |           |  |
| VGSPKZ48<br>063974<br>VGSPKZ250<br>063973<br>VGSPKZ415<br>063972 |                            | 10 off    | For (high-capacity) contact modules with 50-60 Hz AC operation   |
| EZ-PKZ2<br>028596  |                            | 1 off     | For retrofitting of (high-capacity) contact module or current limiter, separate mounting<br><br>With separate contacts also provides fixing base for HI11-S/EZ-PKZ2 auxiliary contacts. Can be snap fitted to an IEC/EN 60715 top-hat rail, or screw fixing M4                           |

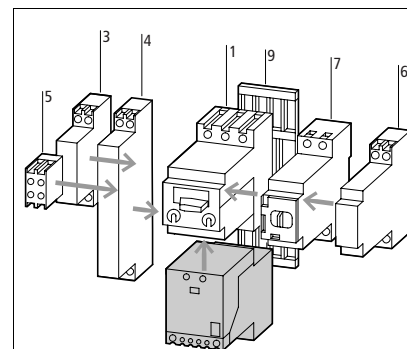

| Accessories  | Page   |
|--|--------|
| 1 Motor-protective circuit-breaker, circuit-breakers | → 8/27 |
| 3 Standard auxiliary contact                         | → 8/35 |
| 4 Standard auxiliary contact                         | → 8/35 |
| 5 Trip-indicating auxiliary contact                  | → 8/35 |
| 6 Shunt release, undervoltage release                | → 8/37 |
| 7 Remote operators                                   | → 8/39 |
| 9 Clip plate   | → 8/44 |
| Further actuating voltages                           | → 8/46 |
| Additional accessories                               | → 8/33 |



HI...-PKZ2

Moeller HPL0211-2007/2008

http://catalog.moeller.net

Contacts  
N/O = Normally  
open      N/C = Normally  
closed

Contact diagram

Contact sequence

**Control circuit terminal****Auxiliary contacts for (high-capacity) contact module, separate mounting**

Can be fitted on side of base for separate mounting

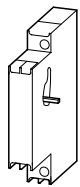

1 N/O

1 N/C

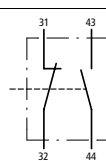
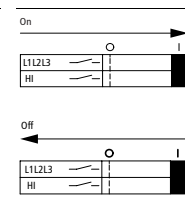
**Auxiliary contacts for (high-capacity) contact module**

Auxiliary contacts to replace integral auxiliary contacts in (high-capacity) contact module.

Replacement not possible with SE1A-G-10-PKZ2 contact module or S-G-PKZ2 high-capacity contact module.



1 N/O

1 N/C

-

-

2 N/O

-

-

-

**Mechanical interlock**

For mechanically interlocking two separately mounted (high-capacity) contact modules or two (high-capacity) compact starters.

Four end brackets supplied

Can be combined with S-PKZ2 high-capacity contact module Serial No. 01.



-

-

http://catalog.moeller.net

Moeller HPL0211-2007/2008

HI...-PKZ2

**Part no.**  
Article no.

**Price**  
see price list

**Std. pack**

**Notes**

ST-PKZ2  
010998

3 off

1 set = 2 off  
Complies with IEC and UL/CSA  
Fast-on connectors can be fitted (insulated/non-insulated) 2.8 mm  
Max. cross-section 0.5 – 1 mm<sup>2</sup>, 20 – 16 AWG  
Max. current tapped off 1 A or 15 % of set value  
Increase setting of overload release accordingly.  
Enables control circuit supply to be tapped off between motor-protective circuit-breaker and (high-capacity) contact module

HI11-S/EZ-PKZ2  
090305

1 off

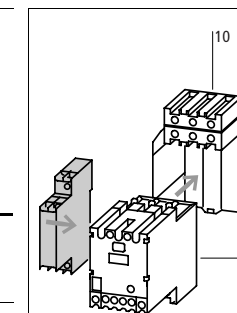
HI11-S-PKZ2  
033936

1 off

HI20-S-PKZ2  
033935

1 off

**Accessories**

8 High-capacity contact module → 8/41  
10 Base for separate mounting → 8/41  
Further actuating voltages → 8/46







**Page**

MV-PKZ2  
033938

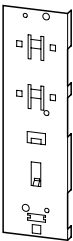
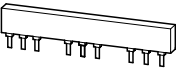
1 off



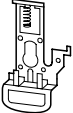

| For use with  | Part no.<br>Article no.      | Price<br>see price<br>list        | Std. pack   |
|---|------------------------------|-----------------------------------|---|
| <b>Clip plate</b>   |                              |                                   |   |
| For optional snap fitting and M4 screw fixing of circuit-breaker with (high-capacity) contact module or current limiter |                              |                                   |   |
| Can be used with AD busbar adapter  | <b>C-PKZ2</b><br>052710      |                                   | 2 off<br>Can be used with AD busbar<br>Can be snap fitted to one IEC/EN 60715 top-hat rail, height 15 mm, or two top-hat rails, greater than 10 mm                              |
|                                        |                              |                                   |   |
| <b>Three-phase commoning link</b>   |                              |                                   |   |
| For wiring 3 PKZ2s, space is provided for either 2 auxiliary contacts or 2 voltage releases                             | <b>B3.1/3-PKZ2</b><br>033940 |                                   | 5 off   |
|                                        |                              |                                   |   |
| For wiring of 2 PKZ2s, space is provided for either 1 auxiliary contact or 1 voltage release                            | <b>B3.1/2-PKZ2</b><br>063969 |                                   | 5 off   |
|                                        |                              |                                   |   |
| <b>Incoming terminal</b>  |                              |                                   |   |
| For three-phase commoning link, protected against accidental contact<br>$U_e = 690 \text{ V}$ , $I_n = 120 \text{ A}$   |                              |                                   |   |
| –   | <b>BK50/3-PKZ2</b><br>033941 |                                   | 2 off<br>For connection of:<br>max. $1 \times 50 \text{ mm}^2$ or $2 \times 35 \text{ mm}^2$ ;<br>above one another min. $1 \times 1 \text{ mm}^2$ or $2 \times 1 \text{ mm}^2$ |
|                                        |                              |                                   |   |
| <b>Shroud for unused terminals</b>  |                              |                                   |   |
| Protection against direct contact.<br>To cover unused terminals on three-phase commoning link                           |                              |                                   |   |
| –   | <b>H-B3-PKZ2</b><br>063968   |                                   | 10 off<br>Snap-fitting option must be available on the three-phase commoning link   |
|                                      |                              |                                   |   |
| <b>Padlocking feature</b>   |                              |                                   |   |
| For locking rear mounting circuit-breakers in the OFF position when the panel door is open.                             |                              |                                   |   |
| –   | <b>SVB-PKZ2</b><br>050337    |                                   | 5 off<br>Suitable for 3 padlocks with 5 – 8 mm hasp thickness   |
|                                      |                              |                                   |   |
| <b>Coding pins</b>  |                              |                                   |   |
| For coding the trip block to match the PKZ2(4) basic unit Coding in binary  |                              |                                   |   |
| –   | <b>CS-PKZ2</b><br>055083     |                                   | 1 off   |
|                                      |                              |                                   |   |
| <b>Documentation</b>  |                              |                                   |   |
| PKZM2 motor-protective circuit-breakers, overload monitoring of EEx e   | German/English               | <b>AWB1210-1485D/GB</b><br>266166 | 1 off   |



| Compact starter<br>Contact modules with 1 N/O and 1 N/C contact |                           |                           |                           |                           |                           |  |
|---|---------------------------|---------------------------|---------------------------|---------------------------|---------------------------|--|
| AC  | PKZ2/ZM-1/SE1A/11(...)    | PKZ2/ZM-1.6/SE1A/11(...)  | PKZ2/ZM-2.4/SE1A/11(...)  | PKZ2/ZM-4/SE1A/11(...)    | PKZ2/ZM-6/SE1A/11(...)    |  |
|   | Article no. <sup>1)</sup> | Article no. <sup>1)</sup> | Article no. <sup>1)</sup> | Article no. <sup>1)</sup> | Article no. <sup>1)</sup> |  |
| Standard voltage  | see price list            | see price list            | see price list            | see price list            | see price list            |  |
| 230V 50Hz,<br>240V 60Hz   | 063364                    | 063372                    | 063382                    | 063392                    | 063402                    |  |
| 110V 50/60Hz  | –                         | –                         | –                         | –                         | 063408                    |  |
| 230V 50/60Hz  | 063369                    | 063379                    | 063389                    | 063399                    | 063409                    |  |

| Compact starter<br>Contact modules with 1 N/O and 1 N/C contact |                           |                           |                           |                           |                           |                           |
|---|---------------------------|---------------------------|---------------------------|---------------------------|---------------------------|---------------------------|
| AC  | PKZ2/ZM-10/SE1A/11(...)   | PKZ2/ZM-16/SE1A/11(...)   | PKZ2/ZM-25/SE1A/11(...)   | PKZ2/ZM-32/SE1A/11(...)   | PKZ2/ZM-40/SE1A/11(...)   | PKZ2/SE1A/11(...)         |
|   | Article no. <sup>1)</sup> | Article no. <sup>1)</sup> | Article no. <sup>1)</sup> | Article no. <sup>1)</sup> | Article no. <sup>1)</sup> | Article no. <sup>1)</sup> |
| Standard voltage  | see price list            | see price list            | see price list            | see price list            | see price list            | see price list            |
| 230V 50Hz,<br>240V 60Hz   | 063412                    | 063422                    | 063432                    | 063442                    | 063452                    | 082142                    |
| 110V 50/60Hz  | 063418                    | 063428                    | 063438                    | 063448                    | 063458                    | –                         |
| 230V 50/60Hz  | 063419                    | 063429                    | 063439                    | 063449                    | 063459                    | 082148                    |

| High-capacity compact starter<br>Contact modules with 1 N/O and 1 N/C auxiliary contact |                           |                           |                           |                           |                           |  |
|---|---------------------------|---------------------------|---------------------------|---------------------------|---------------------------|--|
| AC  | PKZ2/ZM-1/S(...)          | PKZ2/ZM-1.6/S(...)        | PKZ2/ZM-2.4/S(...)        | PKZ2/ZM-4/S(...)          | PKZ2/ZM-6/S(...)          |  |
|   | Article no. <sup>1)</sup> | Article no. <sup>1)</sup> | Article no. <sup>1)</sup> | Article no. <sup>1)</sup> | Article no. <sup>1)</sup> |  |
| Standard voltage  | see price list            | see price list            | see price list            | see price list            | see price list            |  |
| 230V 50Hz,<br>240V 60Hz   | 063472                    | 063482                    | 063492                    | 063502                    | 063512                    |  |
| 110V 50/60Hz  | 063478                    | 063488                    | 063498                    | 063508                    | 063518                    |  |
| 230V 50/60Hz  | 063479                    | 063489                    | 063499                    | 063509                    | 063519                    |  |

| High-capacity compact starter<br>Contact modules with 1 N/O and 1 N/C auxiliary contact |                           |                           |                           |                           |                           |                           |
|---|---------------------------|---------------------------|---------------------------|---------------------------|---------------------------|---------------------------|
| AC  | PKZ2/ZM-10/S(...)         | PKZ2/ZM-16/S(...)         | PKZ2/ZM-25/S(...)         | PKZ2/ZM-32/S(...)         | PKZ2/ZM-40/S(...)         | PKZ2/S(...)               |
|   | Article no. <sup>1)</sup> | Article no. <sup>1)</sup> | Article no. <sup>1)</sup> | Article no. <sup>1)</sup> | Article no. <sup>1)</sup> | Article no. <sup>1)</sup> |
| Standard voltage  | see price list            | see price list            | see price list            | see price list            | see price list            | see price list            |
| 110V 50Hz,<br>120V 60Hz   | –                         | –                         | –                         | –                         | –                         | 063570                    |
| 230V 50Hz,<br>240V 60Hz   | 063522                    | 063532                    | 063542                    | 063552                    | 063562                    | 063572                    |
| 24V 50/60Hz   | –                         | –                         | –                         | –                         | –                         | 063577                    |
| 110V 50/60Hz  | 063528                    | 063538                    | 063548                    | 063558                    | 063568                    | –                         |
| 230V 50/60Hz  | 063529                    | 063539                    | 063549                    | 063559                    | 063569                    | 063579                    |

**Notes**

<sup>1)</sup> The article no. is formed from the combination of part no. and actuating voltage. Devices with **dual-voltage coils** are to be ordered under a **single** order number.



| Undervoltage release  | When ordered separately   |                           |                           |
|---|---------------------------|---------------------------|---------------------------|
|   | U-PKZ2(...)               | U-HI20-PKZ2(...)          | UVHI-PKZ2(...)            |
| AC  | Article no. <sup>1)</sup> | Article no. <sup>1)</sup> | Article no. <sup>1)</sup> |
| Standard voltage  | see price list            | see price list            | see price list            |
| 24V 50Hz  | 055085                    | 063649                    | –                         |
| 110V 50Hz,<br>120V 60Hz   | –                         | 063655                    | –                         |
| 220V 50Hz,<br>240V 60Hz   | 065685                    | 063656                    | –                         |
| 230V 50Hz,<br>240V 60Hz   | 065766                    | 065768                    | 065770                    |
| 400V 50Hz,<br>440V 60Hz   | 065767                    | –                         | –                         |
| 24V 50/60Hz   | –                         | 063659                    | –                         |
| Non-standard voltages with the exception of the shown standard voltages <sup>2)</sup> . | –                         | see price list            | –                         |
| ...V 50Hz (24 – 600V)   | –                         | 907537 <sup>3)</sup>      | –                         |
| ...V 60Hz (24 – 600V)   | –                         | 907538 <sup>3)</sup>      | –                         |
| DC  |                           |                           |                           |
| Standard voltage  | see price list            | –                         | –                         |
| 24V DC  | 014463                    | –                         | –                         |
| 48V DC  | 028701                    | –                         | –                         |

## Notes

- <sup>1)</sup> The article no. is formed from the combination of part no. and actuating voltage.  
Devices with **dual-voltage coils** are to be ordered under a **single** order number.
- <sup>2)</sup> With non-standard voltages the required actuating voltage from the defined range (...-...V) must be stated.
- <sup>3)</sup> Minimum order quantity: 10 units.

## (High capacity)contact module

## Single coil for (high-capacity) contact module

| AC                      | S-PKZ2(...)               | S/HI20-S-PKZ2(...)        | SE1A/11-PKZ2(...)         | SE1A/20-PKZ2(...)         |
|-------------------------|---------------------------|---------------------------|---------------------------|---------------------------|
|                         | Article no. <sup>1)</sup> | Article no. <sup>1)</sup> | Article no. <sup>1)</sup> | Article no. <sup>1)</sup> |
| Standard voltage        | see price list            | see price list            | see price list            | see price list            |
| 24V 50Hz                | 026609                    | –                         | –                         | –                         |
| 48V 50Hz                | 062651                    | 056383                    | –                         | –                         |
| 240V 50Hz               | 001882                    | 057048                    | 058716                    | 058717                    |
| 24V 60Hz                | 062501                    | –                         | –                         | –                         |
| 110V 50Hz,<br>120V 60Hz | 063694                    | 063701                    | 063709                    | 063716                    |
| 190V 50Hz,<br>220V 60Hz | 063695                    | –                         | 063710                    | 063717                    |
| 220V 50Hz,<br>240V 60Hz | 063699                    | 063706                    | –                         | –                         |
| 230V 50Hz,<br>240V 60Hz | 063696                    | 063703                    | 063711                    | 063718                    |
| 400V 50Hz,<br>440V 60Hz | 063697                    | –                         | 063712                    | 063719                    |
| 24V 50/60Hz             | 062500                    | –                         | 058720                    | 058721                    |
| 110V 50/60Hz            | –                         | –                         | 058696                    | –                         |
| 230V 50/60Hz            | 065103                    | 056395                    | 058712                    | 058713                    |
| DC                      | S-G-PKZ2(...)             | SE1A-G-10-PKZ2(...)       |                           |                           |
|                         | Article no. <sup>1)</sup> | Article no. <sup>1)</sup> |                           |                           |
| Standard voltage        | see price list            | see price list            |                           |                           |
| 24V DC                  | 070921                    | 058856                    |                           |                           |

## Notes

- <sup>1)</sup> The article no. is formed from the combination of part no. and actuating voltage.  
Devices with **dual-voltage coils** are to be ordered under a **single** order number.
- <sup>2)</sup> With non-standard voltages the required actuating voltage from the defined range (...-...V) must be stated.



**PKZM0, PKZM4 and PKZ2 in 1 and 2 pole circuits  
for DC and AC**



**Protection of PVC insulated cables against thermal overload with short-circuits**

The table indicates which minimum cable cross-sections are protected by PKZ(M) motor-protective circuit-breakers up to their rated conditional short-circuit current  $I_{cc}$ .

| Min. cross-section protected<br>380 – 415 V, 50 Hz, Cu mm <sup>2</sup> |     |     |   |      |  | Device<br>Part no. | Min. cross-section protected<br>380 – 415 V, 50 Hz, Cu mm <sup>2</sup> |     |     |   |      |  | Device<br>Part no. |
|--|-----|-----|---|------|--|--------------------|--|-----|-----|---|------|--|--------------------|
| 4  | 2,5 | 1,5 | 1 | 0,75 |  |                    | 4  | 2,5 | 1,5 | 1 | 0,75 |  |                    |
|  |     |     |   |      |  | PKZM0-0.16         |  |     |     |   |      |  | PKZ2/ZM-0,6        |
|  |     |     |   |      |  | PKZM0-6.3          |  |     |     |   |      |  | PKZ2/ZM-2.4        |
|  |     |     |   |      |  | PKZM0-10           |  |     |     |   |      |  | PKZ2/ZM-4          |
|  |     |     |   |      |  | PKZM0-12           |  |     |     |   |      |  | PKZ2/ZM-6          |
|  |     |     |   |      |  | PKZM0-16           |  |     |     |   |      |  | PKZ2/ZM-10         |
|  |     |     |   |      |  | PKZM0-20           |  |     |     |   |      |  | PKZ2/ZM-16         |
|  |     |     |   |      |  | PKZM0-25           |  |     |     |   |      |  | PKZ2/ZM-25         |
|  |     |     |   |      |  | PKZM0-32           |  |     |     |   |      |  | PKZ2/ZM-32         |
|  |     |     |   |      |  | PKZM4-16           |  |     |     |   |      |  | PKZ2/ZM-40         |
|  |     |     |   |      |  | PKZM4-25           |  |     |     |   |      |  |                    |
|  |     |     |   |      |  | PKZM4-32           |  |     |     |   |      |  |                    |
|  |     |     |   |      |  | PKZM4-40           |  |     |     |   |      |  |                    |
|  |     |     |   |      |  | PKZM4-50           |  |     |     |   |      |  |                    |
|  |     |     |   |      |  | PKZM4-58           |  |     |     |   |      |  |                    |
| PKZM4-63   |     |     |   |      |  |                    |  |     |     |   |      |  |                    |

**Fuseless installation with PKZ(M), back-up-protection diagrams**

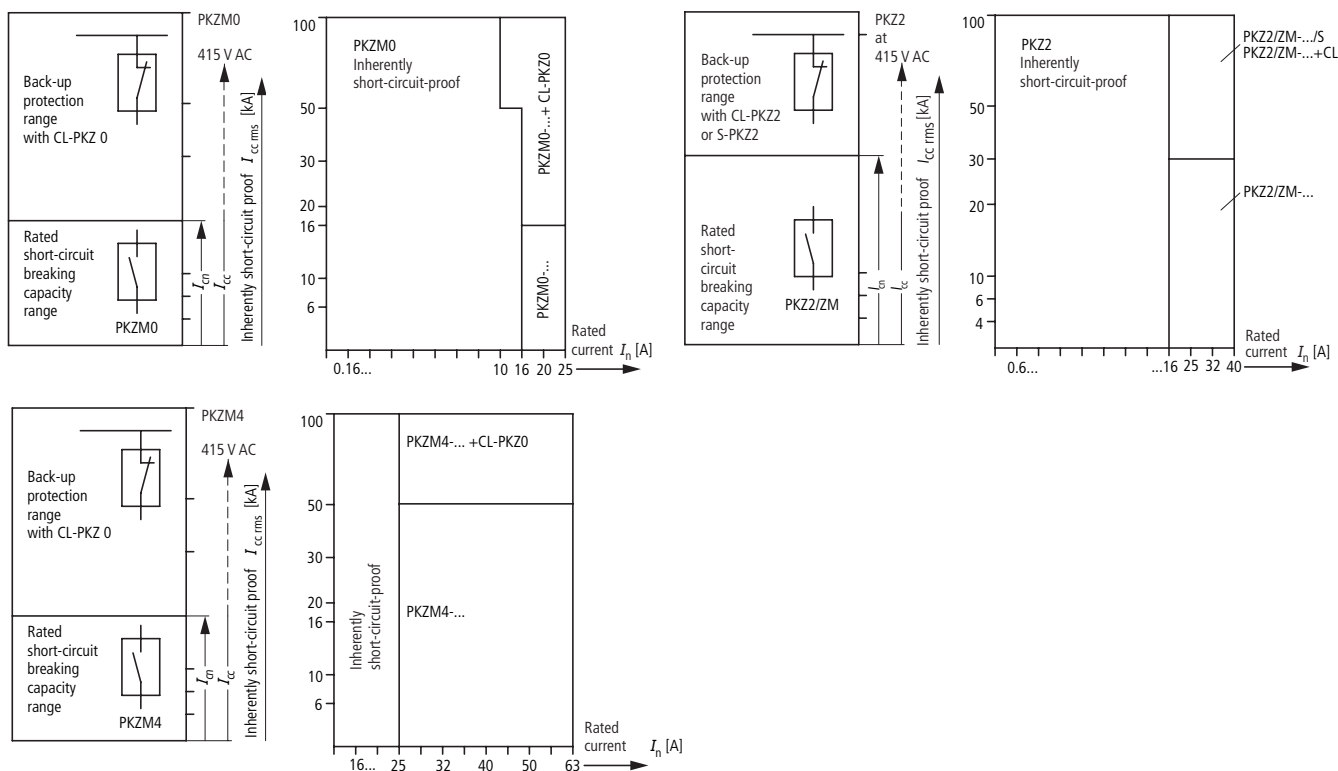

PKZM01, PKZM0, PKZM4, PKZ2 motor-protective circuit-breakers



PKZM

PKZM0...T tripping characteristics (not for PKM0-...), PKZM01

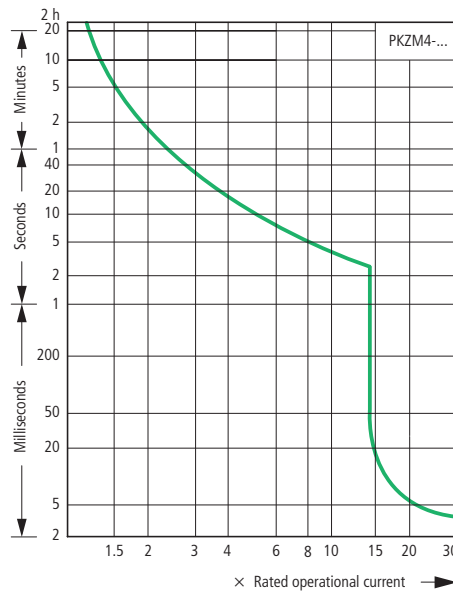
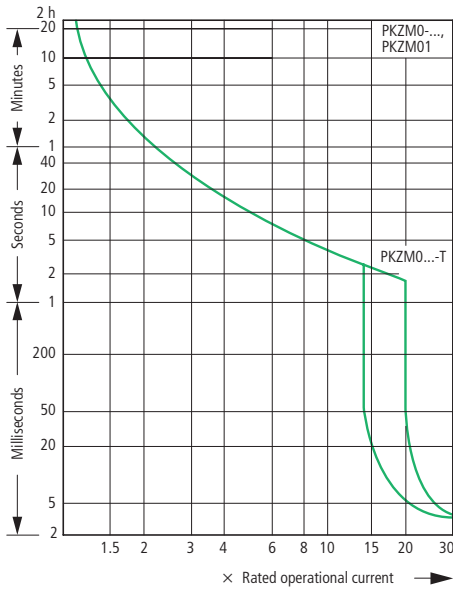

Let-through characteristics, motor-protective circuit-breaker, transformer-protective circuit-breaker, circuit-breaker for starter combinations

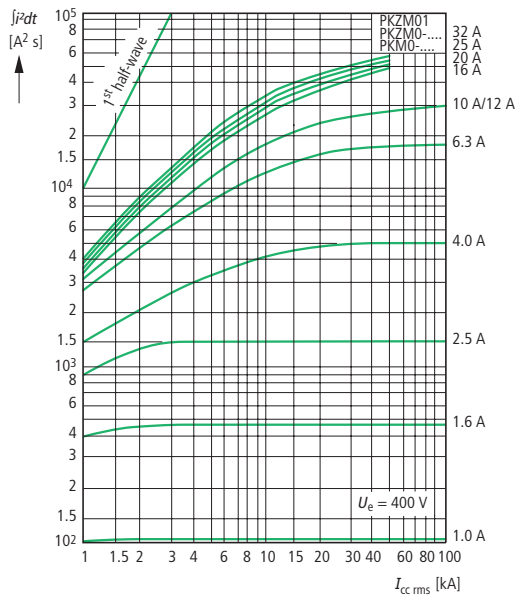
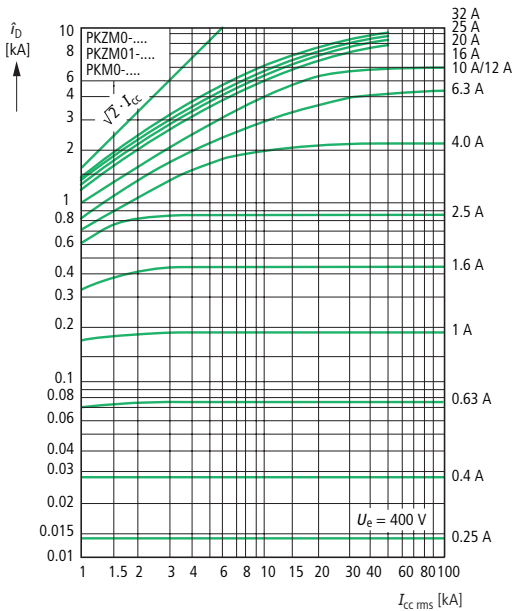

Motor-protective circuit-breaker let-through characteristics

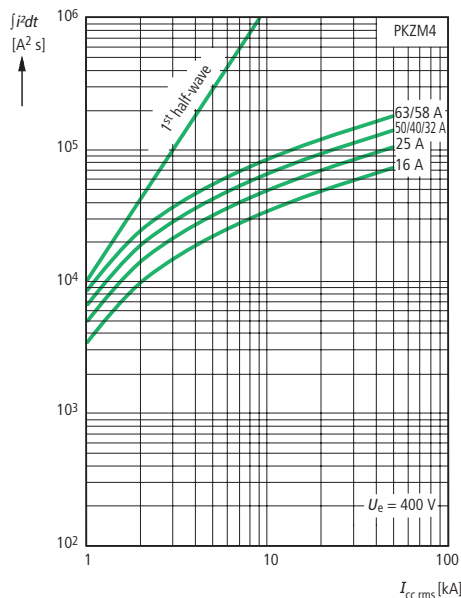
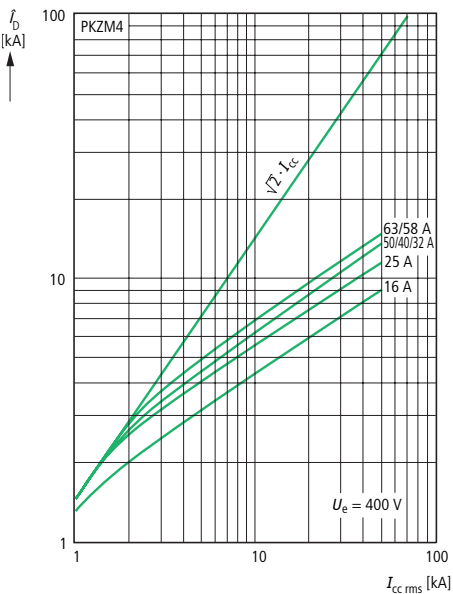

PKZM01, PKZM0, PKZM4, PKZ2 motor-protective circuit-breakers

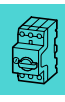

**Circuit-breaker switching capacity from serial no. 04**

Rated uninterrupted current  $I_u$   
 Rated conditional short-circuit current  $I_q$  IEC/EN 60947-4-1  
 Rated ultimate short-circuit breaking capacity  $I_{cu}$   
 Rated service short-circuit breaking capacity  $I_{cs}$  } IEC/EN 60947-2

| $I_u$<br>A | 230 V       |                |                |                 | 400 V       |                |                |                 | 440 V       |                |                |                 | 500 V       |                |                |                 | 690 V       |                |                |                 |
|------------|-------------|----------------|----------------|-----------------|-------------|----------------|----------------|-----------------|-------------|----------------|----------------|-----------------|-------------|----------------|----------------|-----------------|-------------|----------------|----------------|-----------------|
|            | $I_q$<br>kA | $I_{cu}$<br>kA | $I_{cs}$<br>kA | A <sup>1)</sup> | $I_q$<br>kA | $I_{cu}$<br>kA | $I_{cs}$<br>kA | A <sup>1)</sup> | $I_q$<br>kA | $I_{cu}$<br>kA | $I_{cs}$<br>kA | A <sup>1)</sup> | $I_q$<br>kA | $I_{cu}$<br>kA | $I_{cs}$<br>kA | A <sup>1)</sup> | $I_q$<br>kA | $I_{cu}$<br>kA | $I_{cs}$<br>kA | A <sup>1)</sup> |

PKZM0, PKZM0...-T, PKM0 with classification type "1" and "2"

|          |     |     |     |    |     |     |     |    |    |    |    |    |    |    |   |    |   |   |   |    |
|----------|-----|-----|-----|----|-----|-----|-----|----|----|----|----|----|----|----|---|----|---|---|---|----|
| 0,16 – 1 | 150 | 150 | 150 | N  | 150 | 150 | 150 | N  |    |    |    | N  |    |    |   | N  |   |   |   | N  |
| 1,6      | 150 | 150 | 150 | N  | 150 | 150 | 150 | N  |    |    |    | N  |    |    |   | N  |   |   |   | N  |
| 2,5      | 150 | 150 | 150 | N  | 150 | 150 | 150 | N  |    |    |    | N  |    |    |   | N  | 5 | 5 | 5 | 50 |
| 4        | 150 | 150 | 150 | N  | 150 | 150 | 150 | N  |    |    |    | N  |    |    |   | N  | 3 | 3 | 3 | 50 |
| 6,3      | 150 | 150 | 150 | N  | 150 | 150 | 150 | N  |    |    |    | N  | 42 | 42 | 6 | 50 | 3 | 3 | 2 | 50 |
| 10       | 150 | 150 | 150 | N  | 150 | 150 | 150 | N  | 42 | 42 | 10 | 50 | 42 | 42 | 6 | 50 | 3 | 3 | 2 | 50 |
| 12       | 50  | 50  | 10  | 50 | 50  | 50  | 10  | 50 | 15 | 15 | 10 | 50 | 15 | 15 | 6 | 50 | 3 | 3 | 2 | 50 |
| 16       | 50  | 50  | 10  | 50 | 50  | 50  | 10  | 50 | 15 | 15 | 10 | 50 | 15 | 15 | 6 | 50 | 3 | 3 | 2 | 50 |
| 20       | 50  | 50  | 10  | 50 | 50  | 50  | 10  | 50 | 10 | 10 | 10 | 50 | 6  | 6  | 6 | 50 | 3 | 3 | 2 | 50 |
| 25       | 50  | 50  | 10  | 50 | 50  | 50  | 10  | 50 | 10 | 10 | 10 | 50 | 6  | 6  | 6 | 50 | 3 | 3 | 2 | 50 |
| 32       | 50  | 50  | 10  | 50 | 50  | 50  | 10  | 50 | 10 | 10 | 10 | 50 | 6  | 6  | 6 | 50 | 3 | 3 | 2 | 50 |

PKZM0 (PKZM0...-T, PKM0) + CL-PKZO

|          |  |  |  |   |  |  |  |   |  |  |  |   |    |    |    |   |    |    |     |   |
|----------|--|--|--|---|--|--|--|---|--|--|--|---|----|----|----|---|----|----|-----|---|
| 0,16 – 1 |  |  |  | N |  |  |  | N |  |  |  | N |    |    |    | N |    |    | 20  | N |
| 1,6      |  |  |  | N |  |  |  | N |  |  |  | N |    |    |    | N |    |    | 20  | N |
| 2,5      |  |  |  | N |  |  |  | N |  |  |  | N |    |    |    | N | 20 | 20 | 20  | N |
| 4        |  |  |  | N |  |  |  | N |  |  |  | N |    |    |    | N | 20 | 20 | 20  | N |
| 6,3      |  |  |  | N |  |  |  | N |  |  |  | N |    |    | 50 | N | 20 | 20 | 20  | N |
| 10       |  |  |  | N |  |  |  | N |  |  |  | N |    |    | 20 | N | 20 | 20 | 20  | N |
| 12       |  |  |  | N |  |  |  | N |  |  |  | N |    |    | 20 | N | 5  | 5  | 2,5 | N |
| 16       |  |  |  | N |  |  |  | N |  |  |  | N |    |    | 20 | N | 5  | 5  | 2,5 | N |
| 20       |  |  |  | N |  |  |  | N |  |  |  | N | 10 | 10 | 10 | N | 5  | 5  | 2,5 | N |
| 25       |  |  |  | N |  |  |  | N |  |  |  | N | 10 | 10 | 10 | N | 5  | 5  | 2,5 | N |
| 32       |  |  |  | N |  |  |  | N |  |  |  | N | 10 | 10 | 10 | N | 5  | 5  | 2,5 | N |

PKZM0 (PKZM0...-T, PKM0) + 2 CL-PKZO

|          |  |  |  |   |  |  |  |   |  |  |  |   |    |    |    |   |    |    |     |   |
|----------|--|--|--|---|--|--|--|---|--|--|--|---|----|----|----|---|----|----|-----|---|
| 0,16 – 1 |  |  |  | N |  |  |  | N |  |  |  | N |    |    |    | N |    |    | 20  | N |
| 1,6      |  |  |  | N |  |  |  | N |  |  |  | N |    |    |    | N |    |    | 20  | N |
| 2,5      |  |  |  | N |  |  |  | N |  |  |  | N |    |    |    | N | 40 | 40 | 20  | N |
| 4        |  |  |  | N |  |  |  | N |  |  |  | N |    |    |    | N | 40 | 40 | 20  | N |
| 6,3      |  |  |  | N |  |  |  | N |  |  |  | N |    |    | 50 | N | 20 | 20 | 20  | N |
| 10       |  |  |  | N |  |  |  | N |  |  |  | N |    |    | 40 | N | 20 | 20 | 20  | N |
| 12       |  |  |  | N |  |  |  | N |  |  |  | N |    |    | 40 | N | 10 | 10 | 2,5 | N |
| 16       |  |  |  | N |  |  |  | N |  |  |  | N |    |    | 40 | N | 10 | 10 | 2,5 | N |
| 20       |  |  |  | N |  |  |  | N |  |  |  | N | 20 | 20 | 20 | N | 10 | 10 | 2,5 | N |
| 25       |  |  |  | N |  |  |  | N |  |  |  | N | 20 | 20 | 20 | N | 10 | 10 | 2,5 | N |
| 32       |  |  |  | N |  |  |  | N |  |  |  | N | 20 | 20 | 20 | N | 10 | 10 | 2,5 | N |

**Notes**

■ No upstream protective device required, as it is the auto-protected range (100/150 kA)

<sup>1)</sup> Necessary back-up fuse when the short-circuit current exceeds the rated conditional short-circuit current of the device ( $I_{cc} > I_q$ ).

N Not required



**Circuit-breaker switching capacity**

Rated uninterrupted current  $I_u$   
 Rated conditional short-circuit current  $I_q$  IEC/EN 60947-4-1  
 Rated ultimate short-circuit breaking capacity  $I_{cu}$   
 Rated service short-circuit breaking capacity  $I_{cs}$  } IEC/EN 60947-2

| $I_u$<br>A | 230 V       |                |                |                 | 400 V       |                |                |                 | 440 V       |                |                |                 | 500 V       |                |                |                 | 690 V       |                |                |                 |
|------------|-------------|----------------|----------------|-----------------|-------------|----------------|----------------|-----------------|-------------|----------------|----------------|-----------------|-------------|----------------|----------------|-----------------|-------------|----------------|----------------|-----------------|
|            | $I_q$<br>kA | $I_{cu}$<br>kA | $I_{cs}$<br>kA | A <sup>1)</sup> | $I_q$<br>kA | $I_{cu}$<br>kA | $I_{cs}$<br>kA | A <sup>1)</sup> | $I_q$<br>kA | $I_{cu}$<br>kA | $I_{cs}$<br>kA | A <sup>1)</sup> | $I_q$<br>kA | $I_{cu}$<br>kA | $I_{cs}$<br>kA | A <sup>1)</sup> | $I_q$<br>kA | $I_{cu}$<br>kA | $I_{cs}$<br>kA | A <sup>1)</sup> |

PKZM01 with classification type "1" and "2"

|          |    |    |    |    |    |    |    |    |    |    |    |    |    |    |    |    |    |    |    |    |    |
|----------|----|----|----|----|----|----|----|----|----|----|----|----|----|----|----|----|----|----|----|----|----|
| 0.16 – 1 | 50 | 50 | 50 | 50 | 50 | 50 | 50 | 50 | 50 | 50 | 50 | 50 | 50 | 50 | 50 | 50 | 50 | 50 | 50 | 50 |    |
| 1.6      | 50 | 50 | 50 | 50 | 50 | 50 | 50 | 50 | 50 | 50 | 50 | 50 | 50 | 50 | 50 | 50 | 50 | 50 | 50 | 50 |    |
| 2.5      | 50 | 50 | 50 | 50 | 50 | 50 | 50 | 50 | 50 | 50 | 50 | 50 | 50 | 50 | 50 | 50 | 50 | 50 | 50 | 50 |    |
| 4        | 50 | 50 | 50 | 50 | 50 | 50 | 50 | 50 | 50 | 50 | 50 | 50 | 50 | 50 | 50 | 50 | 50 | 50 | 50 | 50 |    |
| 6.3      | 50 | 50 | 50 | 50 | 50 | 50 | 50 | 50 | 50 | 50 | 50 | 50 | 50 | 50 | 50 | 50 | 50 | 50 | 50 | 50 |    |
| 10       | 50 | 50 | 50 | 50 | 50 | 50 | 50 | 50 | 50 | 42 | 42 | 10 | 50 | 42 | 42 | 10 | 50 | 42 | 42 | 10 | 50 |
| 12       | 50 | 50 | 10 | 50 | 50 | 50 | 10 | 50 | 50 | 15 | 15 | 10 | 50 | 15 | 15 | 10 | 50 | 15 | 15 | 10 | 50 |
| 16       | 50 | 50 | 10 | 50 | 50 | 50 | 10 | 50 | 50 | 15 | 15 | 10 | 50 | 15 | 15 | 10 | 50 | 15 | 15 | 10 | 50 |

PKZM4 with classification type "1" and "2"

|    |     |     |    |     |     |     |    |     |    |    |    |     |    |    |     |   |   |     |     |
|----|-----|-----|----|-----|-----|-----|----|-----|----|----|----|-----|----|----|-----|---|---|-----|-----|
| 16 | 150 | 150 | 25 | N   | 150 | 150 | 25 | N   | 45 | 45 | 25 | 100 | 15 | 15 | 100 | 8 | 8 | 2.5 | 100 |
| 25 | 150 | 150 | 25 | N   | 150 | 150 | 25 | N   | 45 | 45 | 25 | 100 | 15 | 15 | 100 | 8 | 8 | 2.5 | 100 |
| 32 | 50  | 50  | 25 | 100 | 50  | 50  | 25 | 100 | 45 | 45 | 25 | 100 | 15 | 15 | 100 | 5 | 5 | 2.5 | 100 |
| 40 | 50  | 50  | 25 | 100 | 50  | 50  | 25 | 100 | 45 | 45 | 25 | 100 | 15 | 15 | 100 | 5 | 5 | 2.5 | 100 |
| 50 | 50  | 50  | 25 | 100 | 50  | 50  | 25 | 100 | 45 | 45 | 25 | 100 | 15 | 15 | 100 | 5 | 5 | 2.5 | 100 |
| 58 | 50  | 50  | 25 | 160 | 50  | 50  | 25 | 160 | 45 | 45 | 25 | 160 | 15 | 15 | 160 | 5 | 5 | 2.5 | 160 |
| 63 | 50  | 50  | 25 | 160 | 50  | 50  | 25 | 160 | 45 | 45 | 25 | 160 | 15 | 15 | 160 | 5 | 5 | 2.5 | 160 |

**Notes**

- No upstream protective device necessary, as it is the auto-protected range (150 kA)
- N Not necessary

<sup>1)</sup> Fuse (A gG/gL) for enhancing the switching capacity of the motor-protective circuit-breaker to 100 kA



### Tripping characteristic, motor-protective circuit-breakers (high-capacity) compact starters

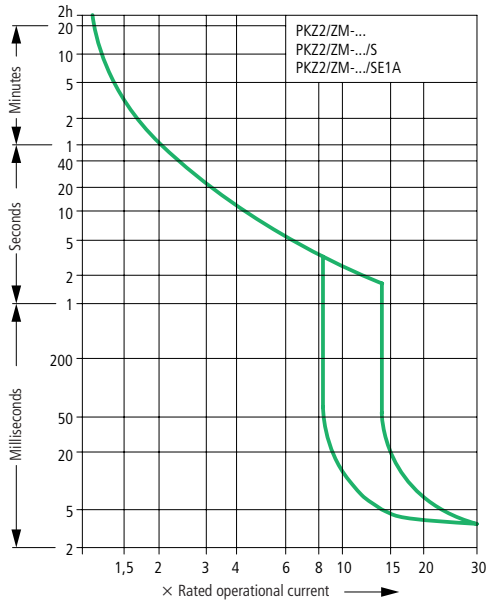

### Tripping characteristics, cable and conductor protection

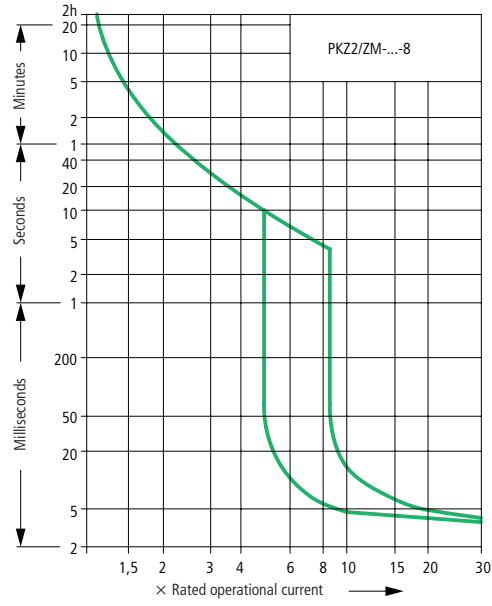

### Let-through characteristics, circuit-breaker, compact starters

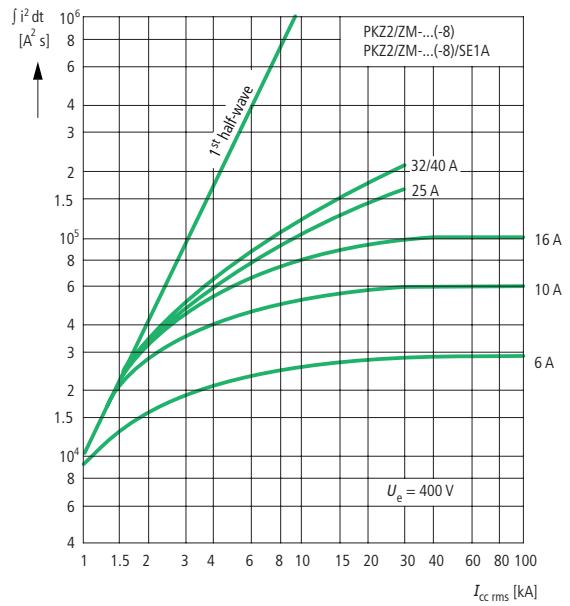
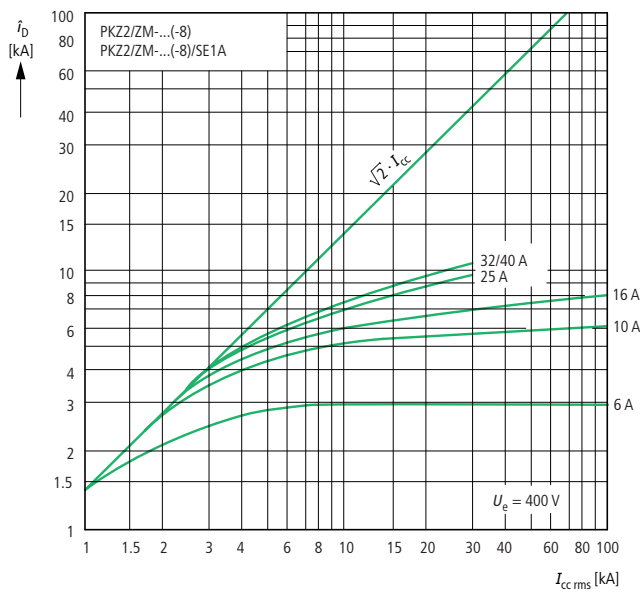

### High-capacity compact starter and circuit-breaker + CL current limiter let-through characteristics

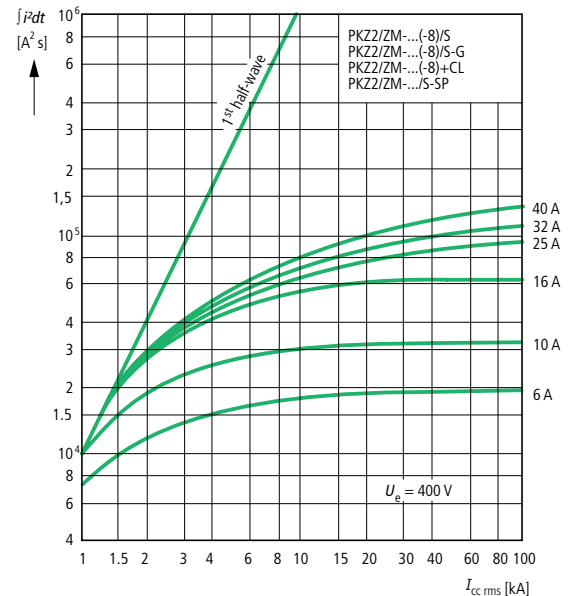
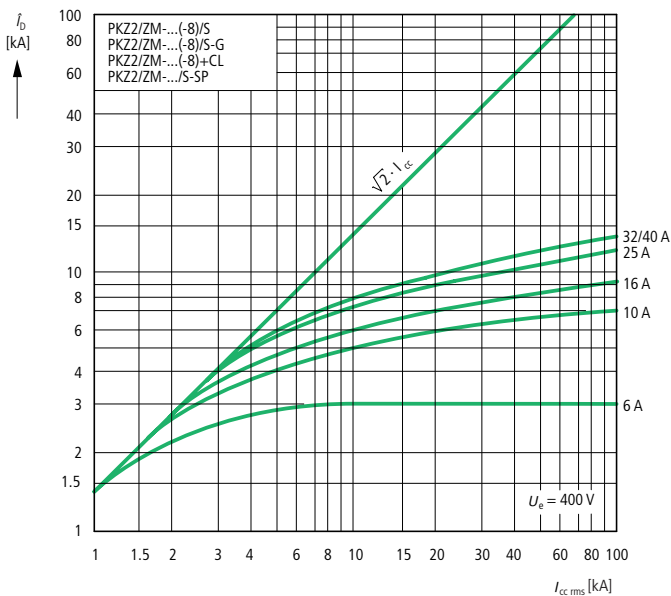



### S-PKZ2 high-capacity contact module, SE1A-PKZ2 contact module

#### Normal switching duty

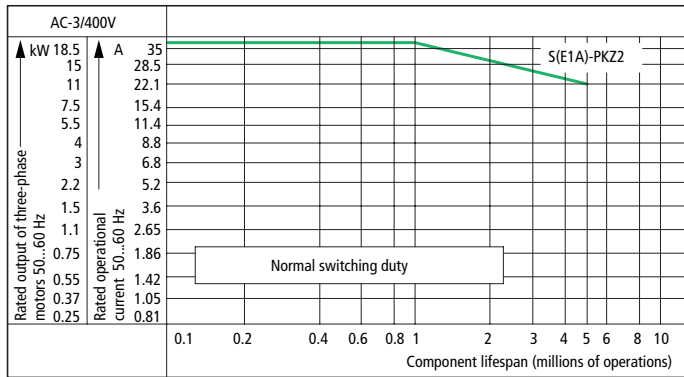

#### Normal AC induction motor

Operating characteristics: Starting: from rest during running  
Stopping: during running

Typical applications: compressors pumps fans valves lifts escalators conveyors bucket-elevators mixers agitators centrifuges air-conditioning systems

General drives for manufacturing and processing machines

Electrical characteristics: Starting: up to 6 × rated motor current  
Stopping: 1 × rated motor current

Utilization category: 100 % AC-3

#### Extreme switching duties

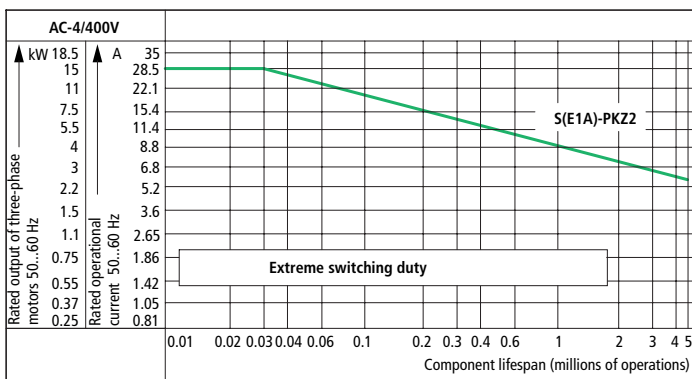

#### Normal AC induction motor

Operating characteristics: Inching, plugging, reversing

Typical applications: printing machines wire-drawing machines centrifuges Special drives on manufacturing and processing machines

Electrical characteristics: Starting: 6 × rated motor current  
Stopping: 6 × rated motor current

Utilization category: 100 % AC-4

#### Light switching duty

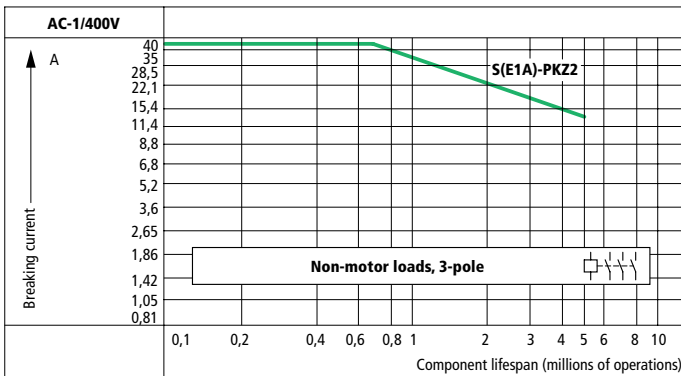

#### Non-motor loads

Operating characteristics: Non inductive and slightly inductive loads

Typical applications: Electrical heaters

Electrical characteristics: Starting: up to 1.5 × rated current  
Stopping: 1 × rated current

Utilization category: 100 % AC-1

### Determination of the maximum operating frequency dependant on the rating and utilization category (recommended values) for (high capacity) contact modules

$P_N$  = max. motor rating (kW) ops/h  
= max. operations per hour

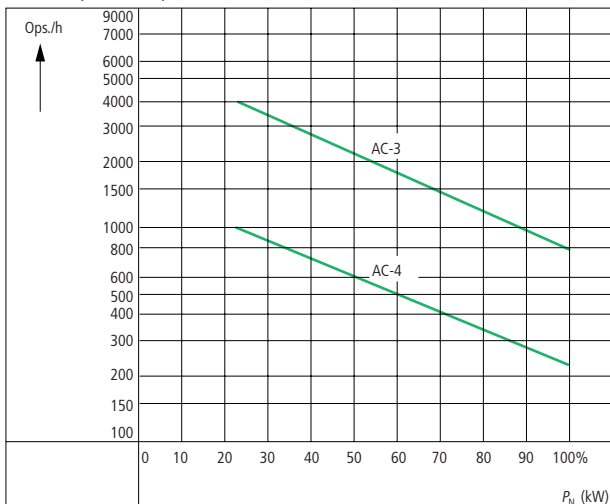

**Motor-protective circuit-breaker switching capacity and (high-capacity) compact starter**

Rated uninterrupted current  $I_u$

Rated conditional short-circuit current  $I_q$  IEC/EN 60 947-4-1

Rated ultimate short-circuit breaking capacity  $I_{cu}$   
Rated service short-circuit breaking capacity  $I_{cs}$  } IEC/EN 60 947-2

| $I_u$<br>A | 230 V       |                |                |   | 400 V       |                |                |   | 440 V       |                |                |   | 500 V       |                |                |   | 690 V       |                |                |   |
|------------|-------------|----------------|----------------|---|-------------|----------------|----------------|---|-------------|----------------|----------------|---|-------------|----------------|----------------|---|-------------|----------------|----------------|---|
|            | $I_q$<br>kA | $I_{cu}$<br>kA | $I_{cs}$<br>kA | A | $I_q$<br>kA | $I_{cu}$<br>kA | $I_{cs}$<br>kA | A | $I_q$<br>kA | $I_{cu}$<br>kA | $I_{cs}$<br>kA | A | $I_q$<br>kA | $I_{cu}$<br>kA | $I_{cs}$<br>kA | A | $I_q$<br>kA | $I_{cu}$<br>kA | $I_{cs}$<br>kA | A |

**PKZ2/ZM with classification type "1" and "2"**

|            |               |  |  |  |               |  |  |  |             |  |  |  |                |  |  |  |
|------------|---------------|--|--|--|---------------|--|--|--|-------------|--|--|--|----------------|--|--|--|
| 0,16 – 1,6 | N             |  |  |  | N             |  |  |  | N           |  |  |  | N              |  |  |  |
| 2,4        | N             |  |  |  | N             |  |  |  | N           |  |  |  | N              |  |  |  |
| 4          | N             |  |  |  | N             |  |  |  | N           |  |  |  | 4,5 4,5 2,5 63 |  |  |  |
| 6          | N             |  |  |  | N             |  |  |  | N           |  |  |  | 4,5 4,5 2,5 80 |  |  |  |
| 10         | 30 N          |  |  |  | 30 N          |  |  |  | 10 10 5 80  |  |  |  | 7 7 3,5 80     |  |  |  |
| 16         | 30 N          |  |  |  | 30 N          |  |  |  | 10 10 5 100 |  |  |  | 7 7 3,5 100    |  |  |  |
| 25         | 30 30 7,5 160 |  |  |  | 30 30 7,5 160 |  |  |  | 10 10 5 125 |  |  |  | 7 7 3,5 125    |  |  |  |
| 32         | 30 30 7,5 160 |  |  |  | 30 30 7,5 160 |  |  |  | 10 10 5 160 |  |  |  | 7 7 3,5 160    |  |  |  |
| 40         | 30 30 7,5 160 |  |  |  | 30 30 7,5 160 |  |  |  | 10 10 5 160 |  |  |  | 7 7 3,5 160    |  |  |  |

**PKZ2/ZM + CL-PKZ2 with classification type "1" and "2"**

|            |       |  |  |  |       |  |  |  |     |  |  |  |              |  |  |  |
|------------|-------|--|--|--|-------|--|--|--|-----|--|--|--|--------------|--|--|--|
| 0,16 – 1,6 | N     |  |  |  | N     |  |  |  | N   |  |  |  | N            |  |  |  |
| 2,4        | N     |  |  |  | N     |  |  |  | N   |  |  |  | N            |  |  |  |
| 4          | N     |  |  |  | N     |  |  |  | N   |  |  |  | 10 4,5 2,5 N |  |  |  |
| 6          | N     |  |  |  | N     |  |  |  | N   |  |  |  | 10 4,5 2,5 N |  |  |  |
| 10         | 30 N  |  |  |  | 30 N  |  |  |  | 5 N |  |  |  | 3,5 N        |  |  |  |
| 16         | 30 N  |  |  |  | 30 N  |  |  |  | 5 N |  |  |  | 3,5 N        |  |  |  |
| 25         | 7,5 N |  |  |  | 7,5 N |  |  |  | 5 N |  |  |  | 3,5 N        |  |  |  |
| 32         | 7,5 N |  |  |  | 7,5 N |  |  |  | 5 N |  |  |  | 3,5 N        |  |  |  |
| 40         | 7,5 N |  |  |  | 7,5 N |  |  |  | 5 N |  |  |  | 3,5 N        |  |  |  |

**PKZ2/ZM(R).../SE1A(-G)... with classification type "1"**

|            |            |  |  |  |            |  |  |  |            |  |  |  |            |  |  |  |
|------------|------------|--|--|--|------------|--|--|--|------------|--|--|--|------------|--|--|--|
| 0,16 – 1,6 | N N N      |  |  |  | N N N      |  |  |  | N N N      |  |  |  | N N N      |  |  |  |
| 2,4        | N N N      |  |  |  | N N N      |  |  |  | N N N      |  |  |  | N N N      |  |  |  |
| 4          | N N N      |  |  |  | N N N      |  |  |  | N N N      |  |  |  | 4,5 N N 63 |  |  |  |
| 6          | N N N      |  |  |  | N N N      |  |  |  | N N N      |  |  |  | 4,5 N N 80 |  |  |  |
| 10         | N N N      |  |  |  | N N N      |  |  |  | 10 N N 80  |  |  |  | 7 N N 80   |  |  |  |
| 16         | N N N      |  |  |  | N N N      |  |  |  | 10 N N 100 |  |  |  | 7 N N 100  |  |  |  |
| 25         | 30 N N 160 |  |  |  | 30 N N 160 |  |  |  | 10 N N 125 |  |  |  | 7 N N 125  |  |  |  |
| 32         | 30 N N 160 |  |  |  | 30 N N 160 |  |  |  | 10 N N 160 |  |  |  | 7 N N 160  |  |  |  |
| 40         | 30 N N 160 |  |  |  | 30 N N 160 |  |  |  | 10 N N 160 |  |  |  | 7 N N 160  |  |  |  |

**PKZ2/ZM-.../S(-G) with classification type "1" and "2"**

|           |     |  |  |  |     |  |  |  |     |  |  |  |            |  |  |  |
|-----------|-----|--|--|--|-----|--|--|--|-----|--|--|--|------------|--|--|--|
| 0,6 – 2,4 | N N |  |  |  | N N |  |  |  | N N |  |  |  | N N        |  |  |  |
| 4 – 6     | N N |  |  |  | N N |  |  |  | N N |  |  |  | 10 N N 80  |  |  |  |
| 10 – 16   | N N |  |  |  | N N |  |  |  | N N |  |  |  | 10 N N 100 |  |  |  |
| 25 – 40   | N N |  |  |  | N N |  |  |  | N N |  |  |  | 10 N N 160 |  |  |  |

**PKZ2/ZM-...-8 and PKZ2/ZM-...-8/SE1A(-G)**

|            |               |  |  |  |               |  |  |  |          |  |  |  |              |  |  |  |
|------------|---------------|--|--|--|---------------|--|--|--|----------|--|--|--|--------------|--|--|--|
| 0,16 – 1,6 | N             |  |  |  | N             |  |  |  | N        |  |  |  | N            |  |  |  |
| 2,4        | N             |  |  |  | N             |  |  |  | N        |  |  |  | N            |  |  |  |
| 4          | N             |  |  |  | N             |  |  |  | N        |  |  |  | N 4,5 2,5 63 |  |  |  |
| 6          | N             |  |  |  | N             |  |  |  | N        |  |  |  | N 4,5 2,5 80 |  |  |  |
| 10         | 30 N          |  |  |  | 30 N          |  |  |  | 10 5 80  |  |  |  | 7 3,5 80     |  |  |  |
| 16         | 30 N          |  |  |  | 30 N          |  |  |  | 10 5 100 |  |  |  | 7 3,5 100    |  |  |  |
| 25         | 30 30 7,5 160 |  |  |  | 30 30 7,5 160 |  |  |  | 10 5 125 |  |  |  | 7 3,5 125    |  |  |  |
| 32         | 30 30 7,5 160 |  |  |  | 30 30 7,5 160 |  |  |  | 10 5 160 |  |  |  | 7 3,5 160    |  |  |  |
| 40         | 30 30 7,5 160 |  |  |  | 30 30 7,5 160 |  |  |  | 10 5 160 |  |  |  | 7 3,5 160    |  |  |  |

**PKZ2/ZM-...-8/S(-G)**

|           |   |  |  |  |   |  |  |  |   |  |  |  |            |  |  |  |
|-----------|---|--|--|--|---|--|--|--|---|--|--|--|------------|--|--|--|
| 0,6 – 2,4 | N |  |  |  | N |  |  |  | N |  |  |  | N          |  |  |  |
| 4 – 6     | N |  |  |  | N |  |  |  | N |  |  |  | N 10 5 80  |  |  |  |
| 10 – 16   | N |  |  |  | N |  |  |  | N |  |  |  | N 10 5 100 |  |  |  |
| 25 – 40   | N |  |  |  | N |  |  |  | N |  |  |  | N 10 5 160 |  |  |  |

**Notes**

■ No upstream protective device required, as it is the auto-protected range (100 kA)

<sup>1)</sup> Fuse (A gG/gL) for enhancing the switching capacity of the motor-protective circuit-breaker to 100 kA

N Not necessary



PKZM

Moeller HPL0211-2007/2008

http://catalog.moeller.net

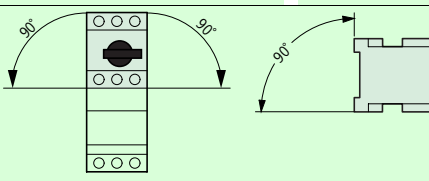
|   |                                    |                              | PKZM01...  | PKZM0-...  |
|---|------------------------------------|------------------------------|--|--|
| <b>General</b>  |                                    |                              |  |  |
| Standards   |                                    |                              | IEC/EN 60947, VDE 0660, UL 508, CSA C 22.2 No. 14                                  |  |
| Climatic proofing   |                                    |                              | Damp heat, constant, to IEC 60068-2-78<br>Damp heat, cyclic, to IEC 60068-2-30     |  |
| Ambient temperature   | Storage                            | °C                           | -25...80   | -25...80   |
|   | Open                               | °C                           | -25...55   | -25...55   |
|   | Enclosed                           | °C                           | -25...40   | -25...40   |
| Mounting position   |                                    |                              |  |  |
| Direction of incoming supply  |                                    |                              | As required  | As required                                      |
| Degree of protection  | Device                             |                              | IP 20  | IP 20  |
|   | Terminations                       |                              | IP00   | IP00   |
| Protection against direct contact   |                                    |                              | Finger and back-of-hand proof  |  |
| Mechanical shock resistance half-sinusoidal shock 10 ms to IEC 60068-2-27 |                                    | g                            | 25   | 25   |
| Altitude  |                                    | m                            | 2000   | 2000   |
| Terminal capacity screw terminals   | Solid                              | mm <sup>2</sup>              | 1 × (1 – 6)<br>2 × (1 – 6)   | 1 × (1 – 6)<br>2 × (1 – 6)                       |
|   | Flexible with ferrule to DIN 46228 | mm <sup>2</sup>              | 1 × (1 – 6)<br>2 × (1 – 6)   | 1 × (1 – 6)<br>2 × (1 – 6)                       |
|   | Solid or stranded                  | AWG                          | 18 – 10  | 18 – 10  |
| Terminal capacity springloaded terminals                                  |                                    |                              |  |  |
| Terminal capacity screw terminals   | Solid                              | mm <sup>2</sup>              |  | 1 × (1...2.5)<br>2 × (1...2.5)                   |
|   | Flexible with ferrule to DIN 46228 | mm <sup>2</sup>              |  | 1 × (1...2.5)<br>2 × (1...2.5)                   |
|   | Solid or stranded                  | AWG                          |  | 18...14  |
| Specified tightening torque for terminal screws                           |                                    |                              |  |  |
| Main cable  |                                    | Nm                           | 1.7  | 1.7  |
| Control circuit cables  |                                    | Nm                           | 1  | 1  |
| <b>Main conducting paths</b>  |                                    |                              |  |  |
| Rated impulse withstand voltage   |                                    | $U_{imp}$ V AC               | 6000   | 6000   |
| Overvoltage category/pollution degree                                     |                                    |                              | III/3  | III/3  |
| Rated operational voltage   |                                    | $U_e$ V AC                   | 690  | 690  |
| Rated uninterrupted current = rated operational current                   |                                    | $I_u = I_e$ A                | 16 or current setting of the overcurrent release                                   | 32 or current setting of the overcurrent release |
| Rated frequency   |                                    | Hz                           | 40 – 60  | 40 – 60  |
| Current heat loss (3 pole at operating temperature)                       |                                    | W                            | 6  | 6  |
| Lifespan, mechanical  |                                    | Operations × 10 <sup>6</sup> | 0.05   | 0.1  |
| Lifespan, electrical (AC-3 at 400 V)                                      |                                    | Operations × 10 <sup>6</sup> | 0.05   | 0.1  |
| Maximum operating frequency   |                                    | Operations/h                 | 25   | 40   |
| Short-circuit rating  |                                    |                              |  |  |
| AC  |                                    |                              | → Engineering  | → Engineering                                    |
| DC  |                                    | kA                           | 60   | 60 (up to PKZM0-16)<br>40 (PKZM0-20 to PKZM0-32) |
| Motor switching capacity  | AC-3 (up to 690 V)                 | A                            | 16   | 32   |
|   | DC-5 (up to 250 V)                 | A                            | 16 (3 contacts in series)  | 25 (3 contacts in series)                        |
| <b>Releases</b>   |                                    |                              |  |  |
| Temperature compensation  |                                    |                              |  |  |
| to IEC/EN 60947, VDE 0660   |                                    | °C                           | -5...40  | -5...40  |
| Operating range   |                                    | °C                           | -25...55   | -25...55   |
| Temperature compensation residual error for T > 40 °C                     |                                    | %/K                          | ≤ 0.25   | ≤ 0.25   |
| Setting range of overload releases  |                                    | × $I_u$                      | 0.6 – 1  | 0.6 – 1  |
| Short-circuit release fixed   |                                    | × $I_u$                      | 14   | 14   |
| Short-circuit release tolerance   |                                    | %                            | ± 20   | ± 20   |
| Phase-failure sensitivity   |                                    |                              | IEC/EN 60947-4-1, VDE 0660 Part 102  |  |

PKZM

http://catalog.moeller.net

Moeller HPL0211-2007/2008

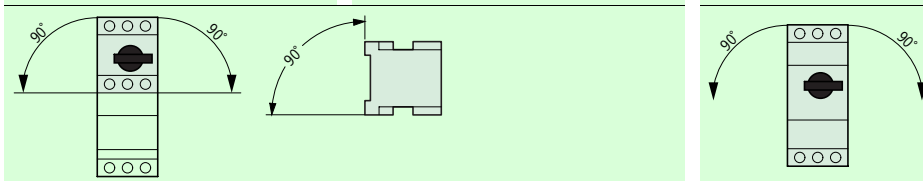
|   |                                    |                              | PKM0-...  | PKZM0-...-T                                      | PKZM4                        |
|---|------------------------------------|------------------------------|---|--|------------------------------|
| <b>General</b>  |                                    |                              |   |  |                              |
| Standards   |                                    |                              | IEC/EN 60947, VDE 0660, UL 508, CSA C 22.2 No. 14                                   |  |                              |
| Climatic proofing   |                                    |                              | Damp heat, constant, to IEC 60068-2-78<br>Damp heat, cyclic, to IEC 60068-2-30      |  |                              |
| Ambient temperature   | Storage                            | °C                           | -25...80  | -25...80   | -25...70                     |
|   | Open                               | °C                           | -25...55  | 25...55  | -25...55                     |
|   | Enclosed                           | °C                           | -25...40  | -25...40   | -25...40                     |
| Mounting position   |                                    |                              |  |  |                              |
| Direction of incoming supply  |                                    |                              | As required   | As required                                      | As required                  |
| Degree of protection  | Device                             |                              | IP 20   | IP 20  | IP 20                        |
|   | Terminations                       |                              | IP00  | IP00   | IP00                         |
| Protection against direct contact   |                                    |                              | Finger and back-of-hand proof   |  |                              |
| Mechanical shock resistance half-sinusoidal shock 10 ms to IEC 60068-2-27 |                                    | g                            | 25  | 25   | 15                           |
| Altitude  |                                    | m                            | 2000  | 2000   | 2000                         |
| Terminal capacity screw terminals   | Solid                              | mm <sup>2</sup>              | 1 × (1 – 6)<br>2 × (1 – 6)  | 1 × (1 – 6)<br>2 × (1 – 6)                       | 1 × (1 – 50)<br>2 × (1 – 35) |
|   | Flexible with ferrule to DIN 46228 | mm <sup>2</sup>              | 1 × (1 – 6)<br>2 × (1 – 6)  | 1 × (1 – 6)<br>2 × (1 – 6)                       | 1 × (1 – 35)<br>2 × (1 – 35) |
|   | Solid or stranded                  | AWG                          | 18 – 10   | 18 – 10  | 14 – 2                       |
| Terminal capacity springloaded terminals                                  |                                    |                              |   |  |                              |
| Terminal capacity screw terminals   | Solid                              | mm <sup>2</sup>              | 1 × (1...2.5)<br>2 × (1...2.5)  |  |                              |
|   | Flexible with ferrule to DIN 46228 | mm <sup>2</sup>              | 1 × (1...2.5)<br>2 × (1...2.5)  |  |                              |
|   | Solid or stranded                  | AWG                          | 18...14   |  |                              |
| Specified tightening torque for terminal screws                           |                                    |                              |   |  |                              |
| Main cable  |                                    | Nm                           | 1.7   | 1.7  | 3                            |
| Control circuit cables  |                                    | Nm                           | 1   | 1  | 1                            |
| <b>Main conducting paths</b>  |                                    |                              |   |  |                              |
| Rated impulse withstand voltage   |                                    | $U_{imp}$ V AC               | 6000  | 6000   | 6000                         |
| Overvoltage category/pollution degree                                     |                                    |                              | III/3   | III/3  | III/3                        |
| Rated operational voltage   |                                    | $U_e$ V AC                   | 690   | 690  | 690                          |
| Rated uninterrupted current = rated operational current                   |                                    | $I_u = I_e$ A                | 32 or current setting of the overcurrent release                                    | 25 or current setting of the overcurrent release | 65 open<br>63 enclosed       |
| Rated frequency   |                                    | Hz                           | 40 – 60   | 40 – 60  | 40 – 60                      |
| Current heat loss (3 pole at operating temperature)                       |                                    | W                            | 6   | 6  | 22                           |
| Lifespan, mechanical  |                                    | Operations × 10 <sup>6</sup> | 0.1   | 0.1  | 0.03                         |
| Lifespan, electrical (AC-3 at 400 V)                                      |                                    | Operations × 10 <sup>6</sup> | 0.1   | 0.1  | 0.03                         |
| Maximum operating frequency   |                                    | Operations/h                 | 40  | 40   | 40                           |
| Short-circuit rating  |                                    |                              |   |  |                              |
| AC  |                                    |                              | → Engineering   | → Engineering                                    | → Engineering                |
| DC  |                                    | kA                           | 60 (up to PKM0-16)<br>40 (PKM0-20 to PKM0-32)                                       | 60 (up to PKZM0-16)<br>40 (PKZM0-20 to PKZM0-32) | 60                           |
| Motor switching capacity  | AC-3 (up to 690 V)                 | A                            | 32  | 25   | 65                           |
|   | DC-5 (up to 250 V)                 | A                            | 25 (3 contacts in series)   | 25 (3 contacts in series)                        | 63 (3 contacts in series)    |
| <b>Releases</b>   |                                    |                              |   |  |                              |
| Temperature compensation  |                                    |                              |   |  |                              |
| to IEC/EN 60947, VDE 0660   |                                    | °C                           | -5...40   | -5...40  | -5...40                      |
| Operating range   |                                    | °C                           | -25...55  | -25...55   | -25...55                     |
| Temperature compensation residual error for T > 40 °C                     |                                    | %/K                          | ≤ 0.25  | ≤ 0.25   | ≤ 0.25                       |
| Setting range of overload releases  |                                    | × $I_u$                      | –   | 0.6 – 1  | 0.6 – 1                      |
| Short-circuit release fixed   |                                    | × $I_u$                      | 14  | 20   | 14                           |
| Short-circuit release tolerance   |                                    | %                            | ± 20  | ± 20   | ± 20                         |
| Phase-failure sensitivity   |                                    |                              | IEC/EN 60947-1-1, VDE 0660 Part 102   |  |                              |



|  |  |                 | NHI...PKZO  | NHI-E-...PKZO | VHI...PKZO | AGM trip indication |
|--|--|-----------------|---|---------------|------------|---------------------|
| <b>Auxiliary contacts</b>  |  |                 |   |               |            |                     |
| Rated impulse withstand voltage  | $U_{imp}$                                | V AC            | 6000  | 4000          | 4000       | 6000                |
| Overvoltage category/pollution degree  |  |                 | III/3   | III/3         | III/3      | III/3               |
| Rated operational voltage  | $U_e$                                    | V AC            | 500   | 440           | 440        | 500                 |
|  | $U_e$                                    | V DC            | 250   | 250           | 250        | 250                 |
| Safe isolation to VDE 0106 Part 101 and Part 101/A1                                    |  |                 |   |               |            |                     |
| Between auxiliary contacts and main contacts   |  | V AC            | 690   | 690           | 690        | 690                 |
| Rated operational current  |  |                 |   |               |            |                     |
| AC-15  |  |                 |   |               |            |                     |
| 220 – 240 V  | $I_e$                                    | A               | 3.5   | 1             | 1          | 3.5                 |
| 380 – 415 V  | $I_e$                                    | A               | 2   | –             | –          | 2                   |
| 440 – 500 V  | $I_e$                                    | A               | 1   | –             | –          | 1                   |
| DC-13 L/R – 100 ms   |  |                 |   |               |            |                     |
| 24 V   | $I_e$                                    | A               | 2   | 2             | 2          | 2                   |
| 60 V   | $I_e$                                    | A               | 1.5   | –             | –          | 1.5                 |
| 110 V  | $I_e$                                    | A               | 1   | –             | –          | 1                   |
| 220 V  | $I_e$                                    | A               | 0.25  | –             | –          | 0.25                |
| Lifespan   |  |                 |   |               |            |                     |
| Lifespan, mechanical   | Operations                               | $\times 10^6$   | 0.1   | 0.1           | 0.1        | 0.01                |
| Lifespan, electrical   | Operations                               | $\times 10^6$   | 0.05  | 0.1           | 0.1        | 0.005               |
| Control circuit reliability (at $U_e = 24$ V DC, $U_{min} = 17$ V, $I_{min} = 5.4$ mA) | Failure rate                             | $\lambda$       | < $10^{-8} < 1$ failure at $1 \times 10^8$ operations |               |            |                     |
| Interlocked opposing contacts to ZH 1/457  |  |                 | Yes   | –             | –          | –                   |
| Short-circuit rating without welding   |  |                 |   |               |            |                     |
| Fuseless   |  |                 | FAZ-B4/1-HI   | –             | –          | FAZ-B4/1-HI         |
| Fuse   |  |                 | 10  | 10            | 10         | 10                  |
| <b>Terminal capacities</b>   |  |                 |   |               |            |                     |
| Solid or flexible conductor with ferrule   |  | mm <sup>2</sup> | 0.75 – 2.5  | 0.75 – 1.5    | 0.75 – 1.5 | 0.75 – 2.5          |
| Solid or stranded  |  | AWG             | 18 – 14   | 18 – 16       | 18 – 16    | 18 – 14             |
| <b>U-PKZ...</b>  |  |                 |   |               |            |                     |
| <b>Undervoltage release</b>  |  |                 |   |               |            |                     |
| Terminal capacities  | Solid or flexible conductor with ferrule | mm <sup>2</sup> | 2 x (0.75 – 2.5)                                      |               |            |                     |
|  | Solid or stranded                        | AWG             | 2 x (18 – 14)   |               |            |                     |
| <b>Main conducting paths</b>   |  |                 |   |               |            |                     |
| Rated operating voltage  |  | $U_e$           | V AC  | 42 – 480      |            |                     |
| Rated operating voltage  |  | $U_e$           | V DC  | 24 – 250      |            |                     |
| Pick-up voltage  |  | $\times U_s$    | 0.85 – 1.1  |               |            |                     |
| Drop-out voltage   |  | $\times U_s$    | 0.7 – 0.35  |               |            |                     |
| Power consumption  | Pick-up AC                               | Pick-up         | VA  | 5             |            |                     |
|  | Sealing AC                               | Sealing         | VA  | 3             |            |                     |
| <b>A-PKZ...</b>  |  |                 |   |               |            |                     |
| <b>Shunt release</b>   |  |                 |   |               |            |                     |
| Terminal capacities  | Solid or flexible conductor with ferrule | mm <sup>2</sup> | 2 x (0.75 – 2.5)                                      |               |            |                     |
|  | Solid or stranded                        | AWG             | 2 x (18 – 14)   |               |            |                     |
| <b>Main conducting paths</b>   |  |                 |   |               |            |                     |
| Rated operating voltage  |  | $U_e$           | V AC  | 42 – 480      |            |                     |
| Rated operating voltage  |  | $U_e$           | V DC  | 24 – 250      |            |                     |
| Operating range  | AC                                       | $\times U_s$    | 0.7...1.1   |               |            |                     |
|  | DC                                       | $\times U_s$    | 0.7...1.1   |               |            |                     |
| Power consumption  |  |                 |   |               |            |                     |
| AC   | Pick-up AC                               | Pick-up         | VA  | 5             |            |                     |
|  | Sealing AC                               | Sealing         | VA  | 3             |            |                     |
| DC   | Pick-up DC                               | Pick-up         | W   | 3             |            |                     |
|  | Sealing DC                               | Sealing         | W   | 3             |            |                     |



Motor-protective circuit-breakers

http://catalog.moeller.net

Moeller HPL0211-2007/2008

PKZ2

|   |                                  |                 | PKZ2/ZM-... (8)  | PKZ2/ZM-... (8)/SE... | PKZ2/ZM-... (8)/S(+CL)    | S(EA)...    |             |
|---|----------------------------------|-----------------|--|-----------------------|---------------------------|-------------|-------------|
| <b>General</b>  |                                  |                 |  |                       |                           |             |             |
| Standards   |                                  |                 | IEC/EN 60947, VDE 0660, UL 508, CSA C 22.2 No. 14, GL, LR, DNV, PRS, BV, RINA, RS, EZU, MEEI |                       |                           |             |             |
| Climatic proofing                                       |                                  |                 | Damp heat, constant, to IEC 60068-2-78;<br>Cyclic to IEC 60068-2-30                          |                       |                           |             |             |
| Ambient temperature                                     | Storage                          | °C              | -25...70   | -25...70              | -25...70                  | -25...70    |             |
|   | Open                             | °C              | -25...60   | -25...60              | -25...60                  | -25...60    |             |
|   | Enclosed                         | °C              | -25...40   | -25...40              | -25...40                  | -25...40    |             |
| Mounting position                                       |                                  |                 |  |                       |                           |             |             |
| Direction of incoming supply                            |                                  |                 | As required  |                       |                           |             |             |
| Protection type   |                                  |                 | IP00   |                       |                           |             |             |
| Mechanical shock resistance                             |                                  |                 |  |                       |                           |             |             |
| Half-sinusoidal shock 20 ms to IEC 60068-2-27           |                                  | g               | 30   | 8                     | 8                         | 8           |             |
| Altitude  |                                  | m               | 2000   |                       |                           |             |             |
| Terminal capacities                                     | Solid or stranded                | mm <sup>2</sup> | 1 x (1 – 16)<br>2 x (1 – 6)  |                       |                           |             |             |
|   | Flexible with ferrule            | mm <sup>2</sup> | 1 x (1.5 – 10)<br>2 x (1.5 – 6)  |                       |                           |             |             |
|   | Solid or stranded                | AWG             | 14 – 6   |                       |                           |             |             |
| Specified tightening torque for terminal screws         | Main cable                       | Nm              | 1.8  |                       |                           |             |             |
|   | Control circuit cables           | Nm              | 1  |                       |                           |             |             |
| <b>Main conducting paths</b>                            |                                  |                 |  |                       |                           |             |             |
| Rated impulse withstand voltage                         |                                  | $U_{imp}$       | V AC   | 6000                  | 6000                      | 6000        | 6000        |
| Overvoltage category/pollution degree                   |                                  |                 |  | III/3                 | III/3                     | III/3       | III/3       |
| Rated operational voltage                               |                                  | $U_e$           | V AC   | 690                   | 690                       | 690         | 690         |
| Rated uninterrupted current = rated operational current |                                  | $I_u = I_e$     | A  | 40                    | 40                        | 40          | 40          |
| Rated frequency   |                                  |                 |  | Hz                    | 50 – 60                   | 50 – 60     | 50 – 60     |
| Current heat loss (3-pole at operating temperature)     |                                  |                 |  | W                     | 14                        | 23          | 23          |
| Lifespan, mechanical                                    |                                  | Operations      | $\times 10^6$  | 0.1                   | 5                         | 5           | 5           |
| Lifespan, electrical                                    | 100 % AC-3                       | Operations      | $\times 10^6$  | 0.05                  | 1                         | 1           | 1           |
|   | AC-4                             | Operations      | $\times 10^6$  | –                     | 0.03                      | 0.03        | 0.03        |
| Maximum operating frequency                             |                                  | Operations/h    | Ops/h  | 60                    | → Projektieren Kennlinien |             |             |
| Motor switching capacity                                | AC-3 (up to 690 V)               |                 |  | A                     | 40                        | 40          | 40          |
|   | DC-5 up to 250 V                 |                 |  | A                     | 40                        | 40          | 40          |
| DC application  |                                  |                 |  |                       |                           |             |             |
| Rated short-circuit breaking capacity $I_{cn}$          | $I_{cn}$ (250 V DC), L/R = 15 ms |                 |  | kA                    | 30                        | 30          | 50          |
|   | $I_{cn}$ (125 V DC), L/R = 15 ms |                 |  | kA                    | 50                        | 50          | 65          |
| Operating times under short-circuit conditions          | Minimum command time             |                 |  | ms                    | Approx. 2                 | Approx. 2   | Approx. 2   |
|   | Opening delay                    |                 |  | ms                    | Approx. 0.5               | Approx. 0.5 | Approx. 0.5 |
|   | Total opening delay              |                 |  | ms                    | 6                         | 6           | 4           |

Notes

With dual-frequency coil 50/60 Hz, the mechanical lifespan reduces by 30%

|   |  |              | ZM-...-PKZ2      | ZMR-...-PKZ2     | ZM-...-8-PKZ2(4)  |
|---|--|--------------|------------------|------------------|-------------------|
| <b>Releases</b>                                       |  |              |                  |                  |                   |
| Function  |  |              | Motor protection | Motor protection | System protection |
| Temperature compensation to IEC/EN 60947, VDE 0660    |  |              |                  |                  |                   |
| Operating range                                       |  | °C           | -5...40          | -5...40          | -5...40           |
| Temperature compensation residual error for T > 40 °C |  | %/K          | ≤ 0.25           | ≤ 0.25           | ≤ 0.25            |
| Short-circuit release tolerance                       |  | %            | ± 20             | ± 20             | ± 20              |
| Setting range of overload releases                    |  | $\times I_u$ | 0.6 – 1          | 0.6 – 1          | 0.6 – 1           |
| Short-circuit releases                                |  | $\times I_u$ | 8.5 – 14         | 8.5 – 14         | 5 – 8.5           |



|   |                  |         |              |  | S(EA)...   |
|---|------------------|---------|--------------|--|------------|
| <b>(High-capacity) contact module</b>         |                  |         |              |  |            |
| Operating delays                              | Closing delay    |         | ms           |  | 9 – 30     |
|   | Opening delay    |         | ms           |  | 4 – 12     |
| Duty factor                                   |                  |         | % DF         |  | 100        |
| Rated making capacity $\cos \varphi = 0.45$   |                  |         | A            |  | 400        |
| Rated breaking capacity $\cos \varphi = 0.45$ |                  |         | A            |  | 400        |
| <b>Magnet systems</b>                         |                  |         |              |  |            |
| AC operation                                  |                  |         |              |  |            |
| Operating range                               | Pick-up voltage  |         | $\times U_s$ |  | 0.85 – 1.1 |
|   | Drop-out voltage |         | $\times U_s$ |  | 0.4 – 0.6  |
| Power consumption                             | Pick-up AC       | Pick-up | VA           |  | 190        |
|   | Sealing AC       | Sealing | VA           |  | 13         |
| DC operation                                  |                  |         |              |  |            |
| Rated control voltage                         |                  | $U_s$   | V DC         |  | 24         |
| Operating range                               | Pick-up voltage  |         | $\times U_s$ |  | 0.85 – 1.1 |
|   |                  |         |              |  |            |
| Power consumption                             | Pick-up DC       | Pick-up | VA           |  | 150        |
|   | Sealing DC       | Sealing | VA           |  | 2.7        |
| Current consumption                           | Pick-up          |         | A            |  | 6.3        |
|   | Sealing          |         | mA           |  | 113        |
| Rated operational current, open, enclosed     |                  |         |              |  |            |
| AC-1  | 230 V            | $I_e$   | A            |  | 40         |
|   | 400 V            | $I_e$   | A            |  | 40         |
|   | 440 V            | $I_e$   | A            |  | 40         |
|   | 500 V            | $I_e$   | A            |  | 40         |
|   | 690 V            | $I_e$   | A            |  | 40         |
| AC-3  | 230 V            | $I_e$   | A            |  | 40         |
|   | 400 V            | $I_e$   | A            |  | 40         |
|   | 440 V            | $I_e$   | A            |  | 40         |
|   | 500 V            | $I_e$   | A            |  | 40         |
|   | 690 V            | $I_e$   | A            |  | 40         |
| AC-4  | 230 V            | $I_e$   | A            |  | 30         |
|   | 400 V            | $I_e$   | A            |  | 30         |
|   | 440 V            | $I_e$   | A            |  | 30         |
|   | 500 V            | $I_e$   | A            |  | 28         |
|   | 690 V            | $I_e$   | A            |  | 25         |

**CL-PKZ2**

|   |                              |          |   |  |     |
|---|------------------------------|----------|---|--|-----|
| <b>Current limiter</b>                        |                              |          |   |  |     |
| Rated making capacity $\cos \varphi = 0.45$   |                              |          | A |  | 400 |
| Rated breaking capacity $\cos \varphi = 0.45$ |                              |          | A |  | 400 |
| AC-1 duty                                     | Conventional thermal current | $I_{th}$ | A |  | 40  |



|   |                   |               |  | NHI11(S)-PKZ2  | NHI22(S)-PKZ2  | NHI2-11S-PKZ2  | AGM2-11-PKZ2   |
|---|-------------------|---------------|--|--|--|--|--|
| <b>Auxiliary contacts</b>   |                   |               |  |  |  |  |  |
| Rated impulse withstand voltage   | $U_{imp}$         | V AC          |  | 6000   | 6000   | 6000   | 6000   |
| Overvoltage category/pollution degree   |                   |               |  | III/3  | III/3  | III/3  | III/3  |
| Rated operational voltage   | $U_e$             | V AC          |  | 500  | 500  | 500  | 500  |
| Rated operational current   |                   |               |  |  |  |  |  |
| AC-15   | 230 – 240 V       | $I_e$         | A  | 6  | 6  | 6  | 5  |
|   | 400 – 415 V       | $I_e$         | A  | 3  | 1.5  | 3  | 3  |
|   | 440 V             | $I_e$         | A  | 1.5  | 1.5  | 1.5  | 1.5  |
|   | 500 V             | $I_e$         | A  | 1.5  | 1.5  | 1.5  | 1.5  |
| Lifespan, mechanical  | Operations        | $\times 10^6$ |  | 0.1  | 0.1  | 5  | 0.01   |
| Lifespan, electrical  | Operations        | $\times 10^6$ |  | 0.05   | 0.05   | 1  | 0.005  |
| Control circuit reliability (at $U_e = 24$ V DC, $U_{min} = 17$ V, $I_{min} = 10$ mA) | Failure rate      | $\lambda$     | Control circuit reliability through the entire mechanical lifespan |  |  |  |  |
| Interlocked opposing contacts to ZH 1/457   |                   |               |  | –  | –  | Yes  | Yes  |
| Short-circuit rating without welding  |                   |               |  |  |  |  |  |
| Fuseless  |                   |               |  | 240 V: PKZM0-6,3<br>415 V: PKZM0-4<br>500 V: PKZM0-1,6 | 240 V: PKZM0-6,3<br>415 V: PKZM0-4<br>500 V: PKZM0-1,6 | 240 V: PKZM0-6,3<br>415 V: PKZM0-4<br>500 V: PKZM0-1,6 | 240 V: PKZM0-6,3<br>415 V: PKZM0-4<br>500 V: PKZM0-1,6 |
|   | Fuse              |               | A gG/gL  | 10   | 10   | 10   | 10   |
| Terminal capacities   |                   |               |  |  |  |  |  |
| Solid or flexible conductor with ferrule  |                   |               | mm <sup>2</sup>  | 1 $\times$ (0.75 – 2.5)<br>2 $\times$ (0.75 – 2.5)     | 1 $\times$ (0.75 – 2.5)<br>2 $\times$ (0.75 – 2.5)     | 1 $\times$ (0.75 – 2.5)<br>2 $\times$ (0.75 – 2.5)     | 1 $\times$ (0.75 – 2.5)<br>2 $\times$ (0.75 – 2.5)     |
|   | Solid or stranded |               | AWG  | 1 $\times$ (22 – 14)<br>2 $\times$ (22 – 14)           | 1 $\times$ (22 – 14)<br>2 $\times$ (22 – 14)           | 1 $\times$ (22 – 14)<br>2 $\times$ (22 – 14)           | 22 – 14  |
| Safe isolation to VDE 0106 Part 101 and Part 101/A1                                   |                   |               |  |  |  |  |  |
| Between auxiliary contacts and main contacts  |                   | V AC          |  | 690  | 690  | 500  |  |
|   |                   |               |  | HI...S-PKZ2  | HI11-S/EZ-PKZ2   | ZMR...(95 – 96)  | ZMR...(97 – 98)  |
| <b>Auxiliary contacts</b>   |                   |               |  |  |  |  |  |
| Rated impulse withstand voltage   | $U_{imp}$         | V AC          |  | 6000   | 6000   | 6000   | 6000   |
| Overvoltage category/pollution degree   |                   |               |  | III/3  | III/3  | III/3  | III/3  |
| Rated operational voltage   | $U_e$             | V AC          |  | 500  | 500  | 500  | 500  |
| Rated operational current   |                   |               |  |  |  |  |  |
| AC-15   | 230 – 240 V       | $I_e$         | A  | 6  | 6  | 1.5  | 1.5  |
|   | 400 – 415 V       | $I_e$         | A  | 1.5  | 3  | 0.7  | 0.5  |
|   | 440 V             | $I_e$         | A  | 1.5  | 1.5  | 0.5  | 0.3  |
|   | 500 V             | $I_e$         | A  | 1.5  | 1.5  | 0.5  | 0.3  |
| Lifespan, mechanical  | Operations        | $\times 10^6$ |  | 5  | 5  | 0.01   | 0.01   |
| Lifespan, electrical  | Operations        | $\times 10^6$ |  | 1  | 1  | 0.005  | 0.005  |
| Control circuit reliability (at $U_e = 24$ V DC, $U_{min} = 17$ V, $I_{min} = 10$ mA) | Failure rate      | $\lambda$     | Control circuit reliability through the entire mechanical lifespan |  |  |  |  |
| Interlocked opposing contacts to ZH 1/457   |                   |               |  | –  | –  | –  | –  |
| Short-circuit rating without welding  |                   |               |  |  |  |  |  |
| Fuseless  |                   |               |  | 240 V: PKZM0-6,3<br>415 V: PKZM0-4<br>500 V: PKZM0-1,6 | 240 V: PKZM0-6,3<br>415 V: PKZM0-4<br>500 V: PKZM0-1,6 | –  | –  |
|   | Fuse              |               | A gG/gL  | 10   | 10   | 10   | 10   |
| Terminal capacities   |                   |               |  |  |  |  |  |
| Solid or flexible conductor with ferrule  |                   |               | mm <sup>2</sup>  | 1 $\times$ (0.75 – 2.5)<br>2 $\times$ (0.75 – 2.5)     | 1 $\times$ (0.75 – 2.5)<br>2 $\times$ (0.75 – 2.5)     | 1 $\times$ (0.75 – 2.5)<br>2 $\times$ (0.75 – 2.5)     | 1 $\times$ (0.75 – 2.5)<br>2 $\times$ (0.75 – 2.5)     |
|   | Solid or stranded |               | AWG  | 22 – 14  | 22 – 14  | 22 – 14  | 22 – 14  |
| Safe isolation to VDE 0106 Part 101 and Part 101/A1                                   |                   |               |  |  |  |  |  |
| Between auxiliary contacts and main contacts  |                   | V AC          |  | 500  | 500  | –  | –  |



U-PKZ, A-PKZ

Moeller HPL0211-2007/2008

<http://catalog.moeller.net>

|  |              |                 |  | U-PKZ2...                            | U-HI20-PKZ2...                       | UVHI-PKZ2                            |
|--|--------------|-----------------|--|--------------------------------------|--------------------------------------|--------------------------------------|
| <b>Undervoltage release</b>              |              |                 |  |                                      |                                      |                                      |
| Rated impulse withstand voltage          | $U_{imp}$    | V AC            |  | 6000                                 | 6000                                 | 6000                                 |
| Overvoltage category/pollution degree    |              |                 |  | III/3                                | III/3                                | III/3                                |
| Terminal capacities                      |              |                 |  |                                      |                                      |                                      |
| Solid or flexible conductor with ferrule |              | mm <sup>2</sup> |  | 1 × (0.75 – 2.5)<br>2 × (0.75 – 2.5) | 1 × (0.75 – 2.5)<br>2 × (0.75 – 2.5) | 1 × (0.75 – 2.5)<br>2 × (0.75 – 2.5) |
| Solid or stranded                        |              | AWG             |  | 22 – 14                              | 22 – 14                              | 22 – 14                              |
| Rated operating voltage                  | $U_e$        | V AC            |  | 24 – 600                             | 24 – 600                             | 24 – 600                             |
| Rated operating voltage                  | $U_e$        | V DC            |  | 24 – 125                             | 24 – 125                             | 24 – 125                             |
| Drop-out voltage                         | $\times U_s$ | V               |  | 0.7 – 0.35                           | 0.7 – 0.35                           | 0.7 – 0.35                           |
| Power consumption                        |              |                 |  |                                      |                                      |                                      |
| AC                                       |              |                 |  |                                      |                                      |                                      |
| Pick-up AC                               | Pick-up      | VA              |  | 5                                    | 5                                    | 5                                    |
| Sealing AC                               | Sealing      | VA              |  | 3                                    | 3                                    | 3                                    |
| DC                                       |              |                 |  |                                      |                                      |                                      |
| Pick-up DC                               | Pick-up      | W               |  | 3                                    | 3                                    | 3                                    |
| Sealing DC                               | Sealing      | W               |  | 3                                    | 3                                    | 3                                    |
| Off-delay                                |              | ms              |  | –                                    | –                                    | 200                                  |
| Rated operational current                |              |                 |  |                                      |                                      |                                      |
| AC-15                                    |              |                 |  |                                      |                                      |                                      |
| 230 V                                    | $I_e$        | A               |  | –                                    | 6                                    | 6                                    |
| 400 V                                    | $I_e$        | A               |  | –                                    | 3                                    | 3                                    |
| 440 V                                    | $I_e$        | A               |  | –                                    | 1.5                                  | 1.5                                  |

## A-PKZ2...

**Shunt release**

|  |           |                 |  |                                      |
|--|-----------|-----------------|--|--------------------------------------|
| Rated impulse withstand voltage          | $U_{imp}$ | V AC            |  | 6000                                 |
| Overvoltage category/pollution degree    |           |                 |  | III/3                                |
| Terminal capacities                      |           |                 |  |                                      |
| Solid or flexible conductor with ferrule |           | mm <sup>2</sup> |  | 1 × (0.75 – 2.5)<br>2 × (0.75 – 2.5) |
| Solid or stranded                        |           | AWG             |  | 22 – 14                              |
| Rated operating voltage                  | $U_e$     | V AC            |  | 24 – 600                             |
| Rated operating voltage                  | $U_e$     | V DC            |  | 24 – 250                             |
| Operating range                          |           |                 |  |                                      |
| Alternating voltage                      |           | $\times U_s$    |  | 0.7 – 1.1                            |
| DC                                       |           | $\times U_s$    |  | 0.7 – 1.1                            |
| Power consumption                        |           |                 |  |                                      |
| AC                                       |           |                 |  |                                      |
| Pick-up AC                               | Pick-up   | VA              |  | 5                                    |
| Sealing AC                               | Sealing   | VA              |  | 3                                    |
| DC                                       |           |                 |  |                                      |
| Pick-up DC                               | Pick-up   | W               |  | 3                                    |
| Sealing DC                               | Sealing   | W               |  | 0.3                                  |

## BK...-PKZ2, B3.1/...-PKZ2

**Incoming terminal and three-phase current**

|                                       |           |      |  |       |
|---------------------------------------|-----------|------|--|-------|
| Rated impulse withstand voltage       | $U_{imp}$ | V AC |  | 6000  |
| Overvoltage category/pollution degree |           |      |  | III/3 |
| Rated operational voltage             | $U_e$     | V AC |  | 690   |
| Rated uninterrupted current           | $I_u$     | A    |  | 120   |





|  |                     |                 | RE-PKZ2  | RS-PKZ2  |
|--|---------------------|-----------------|--|--|
| <b>Remote operator</b>   |                     |                 |  |  |
| Rated impulse withstand voltage  | $U_{imp}$           | V AC            | 6000   | 6000   |
| Overvoltage category/pollution degree  |                     |                 | III/3  | III/3  |
| Rated operating voltage  | $U_e$               | V AC            | 380 – 440  | 380 – 440  |
| Rated operating voltage  | $U_e$               | V DC            | 24 – 240   | 24 – 240   |
| Safe isolation to VDE 0106 Part 101 and Part 101 A1 between auxiliary contacts and main contacts |                     | V AC            | 500  | 500  |
| Required short-time rating (30 ms)   |                     | VA/W            | 700  | 700  |
| Control transformer short-time rating  |                     | VA              | 1000   | 1000   |
| Shortcircuit voltage   |                     | %               | 4.4  | 4.4  |
| Closing delay  |                     | ms              | 30   | 30   |
| Opening delay  |                     | ms              | 30   | 30   |
| Reset time to Off  |                     | ms              | 30   | 30   |
| Maximum operating frequency  |                     | Ops/h           | 60   | 60   |
| Operating range  | Alternating voltage | $\times U_s$    | 0.85 – 1.1   | 0.85 – 1.1   |
|  | DC                  | $\times U_s$    | 0.85 – 1   | 0.85 – 1   |
| Lifespan, electrical   | Operations          | $\times 10^6$   | 0.05   | 0.05   |
| Integral auxiliary contacts (make contact 33/34 Hand/Auto indication)                            |                     |                 |  |  |
| Conventional free air thermal current th   | $I_{th}$            | A               | 1.5  | 1.5  |
| Rated operational current  |                     |                 |  |  |
| AC—14  | 230/240 V           | $I_e$           | A  | 1.5  |
|  | 400/415 V           | $I_e$           | A  | 1  |
|  | 440 V               | $I_e$           | A  | 0.5  |
| Terminal capacities  |                     |                 |  |  |
| Solid or flexible conductor with ferrule   |                     | mm <sup>2</sup> | 1 $\times$ (0.75 – 2.5)<br>2 $\times$ (0.75 – 2.5) | 1 $\times$ (0.75 – 2.5)<br>2 $\times$ (0.75 – 2.5) |
| Solid or stranded  |                     | AWG             | 22 – 14  | 22 – 14  |

BK...-PKZ2, B3.1/...-PKZ2

|  |           |      |       |  |
|--|-----------|------|-------|--|
| <b>Incoming terminal and three-phase current</b> |           |      |       |  |
| Rated impulse withstand voltage                  | $U_{imp}$ | V AC | 6000  |  |
| Overvoltage category/pollution degree            |           |      | III/3 |  |
| Rated operational voltage                        | $U_e$     | V AC | 690   |  |
| Rated uninterrupted current                      | $I_u$     | A    | 120   |  |



### PKZM01, PKZM0

Motor-protective circuit-breakers

PKZM01...

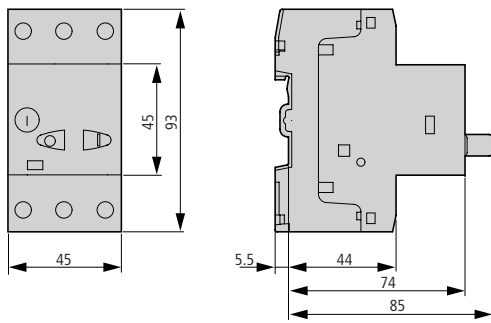

Motor-protective circuit-breakers

Transformer-protective circuit-breakers  
Motor-protective circuit-breaker with standard auxiliary contact

PKZM0-...(+NHI-E-...-PKZ0)  
PKZM0-...-T(+NHI-E-...-PKZ0)  
PKM0-...(+NHI-E-...-PKZ0)

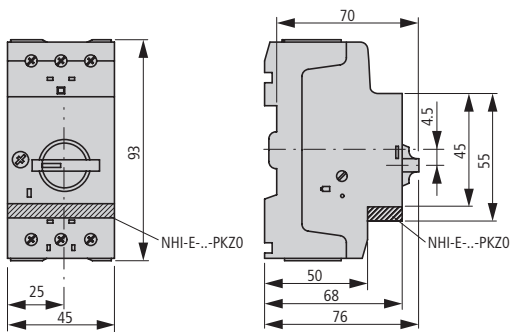

Motor-protective circuit-breakers with lockable rotary handles

PKZM0-...+AK-PKZ0

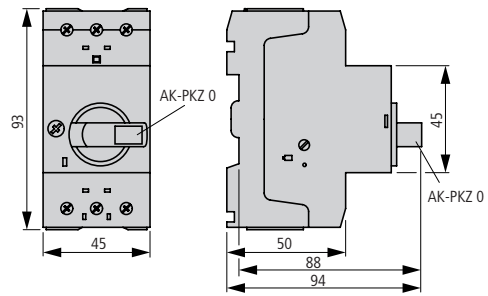

Current limiters

CL-PKZ...

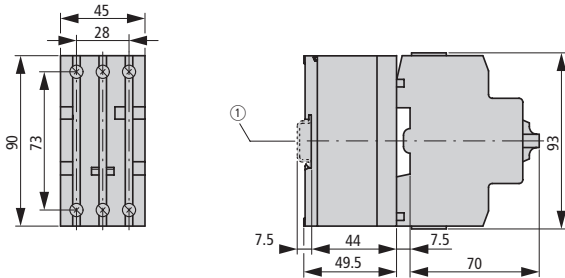

Motor-protective circuit-breakers with early-make auxiliary contacts

PKZM0-...+VHI-...-PKZ0

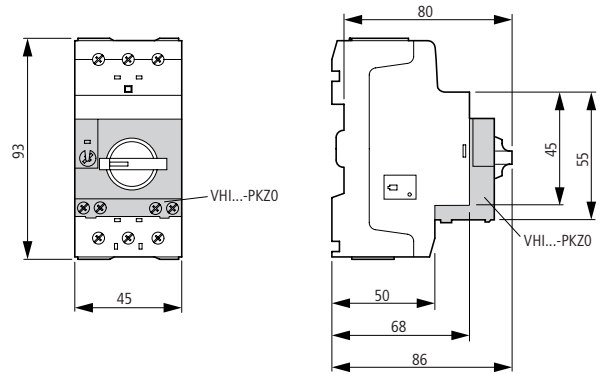

Standard auxiliary contacts

NHI...-PKZ0

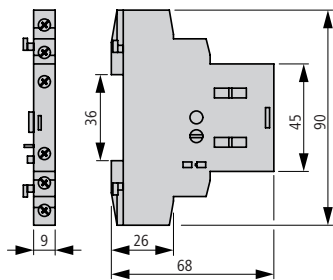

Trip-indicating auxiliary contacts

AGM2...-PKZ0

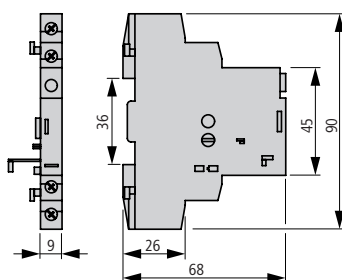

Shunt releases  
Undervoltage releases

A-PKZ0...  
U-PKZ0...

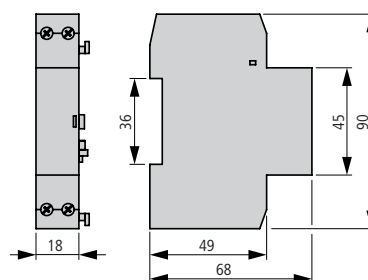

**PKZ0**

Three-phase commoning links

- B3.0/4-PKZ0
- B3.0/2-PKZ0

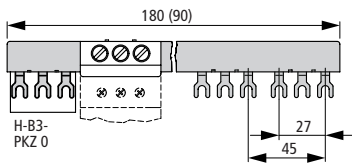

Three-phase commoning links

- B3.2/4-PKZ0
- B3.2/2-PKZ0

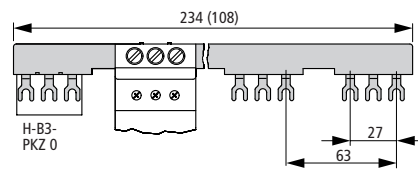

Three-phase commoning links

- B3.1/5-PKZ0
- B3.1/4-PKZ0
- B3.1/3-PKZ0
- B3.1/2-PKZ0

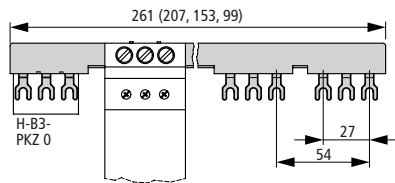

Overlapping mounting to extend the three-phase commoning link

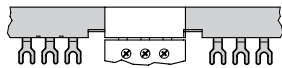

Incoming terminal

- BK25/3-PKZ0

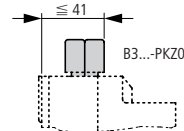
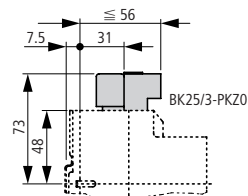

Three-phase commoning links

- B3.0/5-PKZ0-U
- B3.0/4-PKZ0-U
- B3.0/3-PKZ0-U
- B3.0/2-PKZ0-U

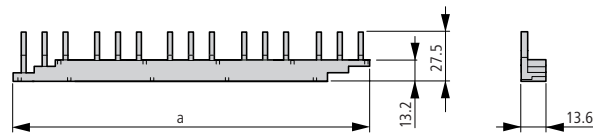

Three-phase commoning links

- B3.1/5-PKZ0-U
- B3.1/4-PKZ0-U
- B3.1/3-PKZ0-U
- B3.1/2-PKZ0-U

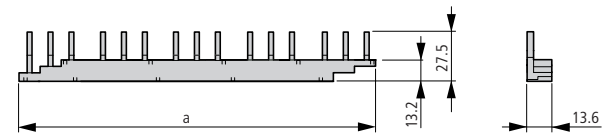

| Part no.   | a   |
|------------|-----|
| B3.0/5-... | 215 |
| B3.0/4-... | 170 |
| B3.0/3-... | 125 |
| B3.0/2-... | 80  |

| Part no.   | a   |
|------------|-----|
| B3.0/5-... | 215 |
| B3.0/4-... | 170 |
| B3.0/3-... | 125 |
| B3.0/2-... | 80  |

Incoming terminal

- BK25/3-PKZ0-U

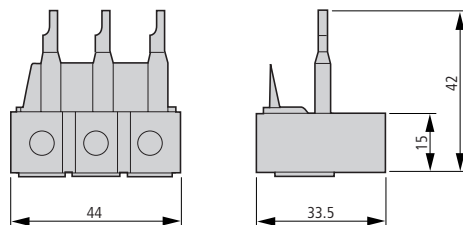

PKZMO

Insulated enclosure for top mounting  
CI-PKZ0-M

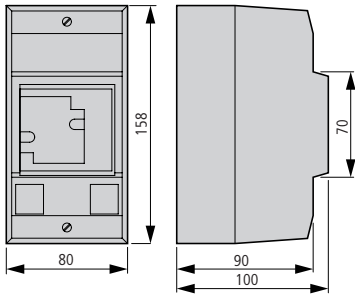

CI-PKZ0-G...M

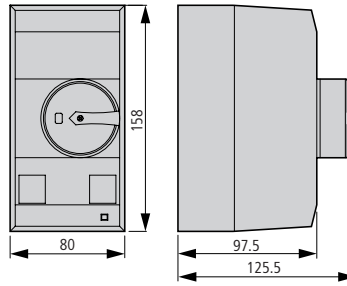

CI-K2-PKZ0-...M + SVB-PKZ0-CI  
CI-K2-PKZ0-...M + SVB-PKZ0-CI

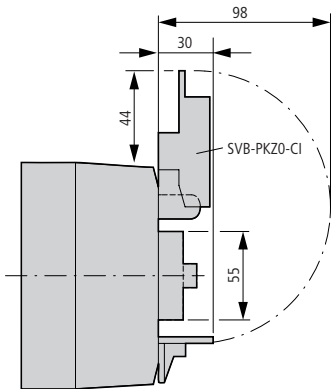

CI-K2-PKZ0-...M + SVB-PKZ0-CI  
CI-PKZ0-...M

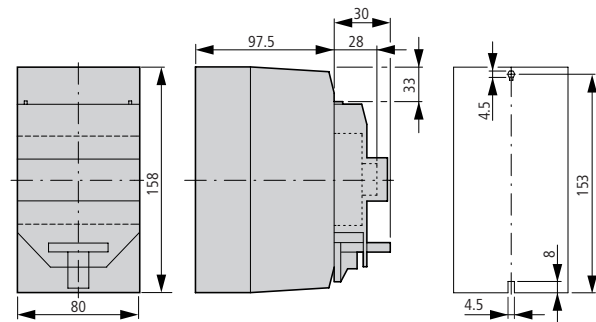

CI-K2-PKZ0

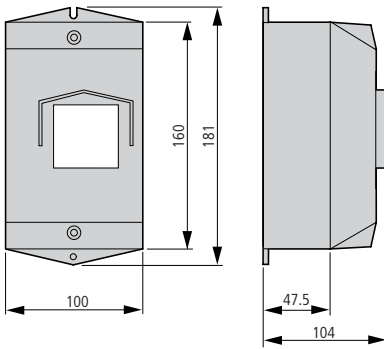

CI-K2-PKZ0G(R)(V)

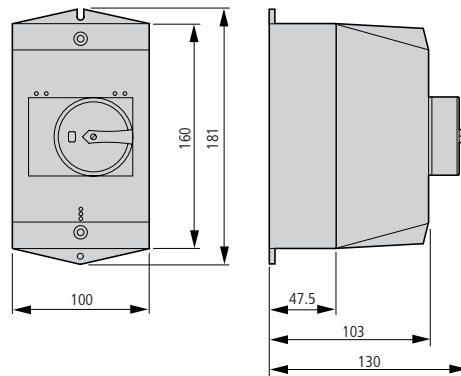

CI-K2-PKZ0-G(R)(V) + SVB-PKZ0-CI  
CI-K2-PKZ0-G(R)(V) + SVB-PKZ0-CI

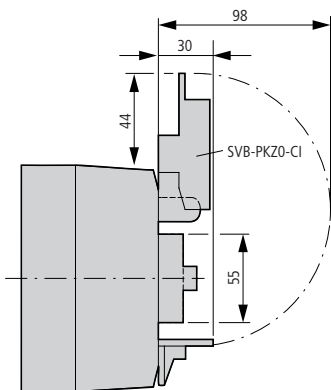

CI-K2-PKZ0...  
CI-K2-PKZ0...

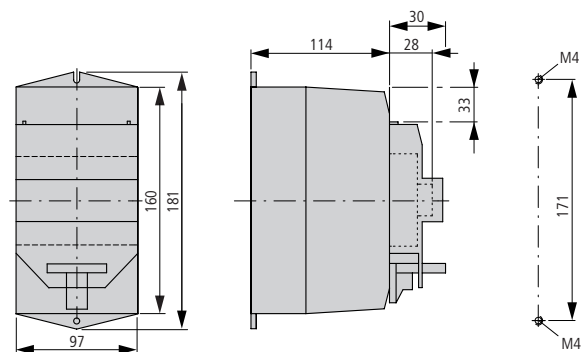

Door coupling handles  
PKZ0-XH

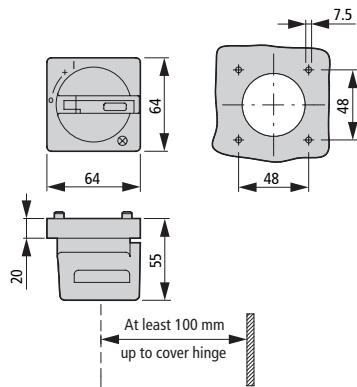

Mounting depth: 100 to 240 mm from top edge of DIN top-hat rail up to front of panel door/cover  
Clearance of switch shaft/cover hinge: at least 100 mm

Motor-protective circuit-breakers  
PKZM01, PKZM0, PKZM4

Insulated enclosure for flush mounting  
E-PKZ0  
E-PKZ0-G

E-PKZ0... mounting aperture

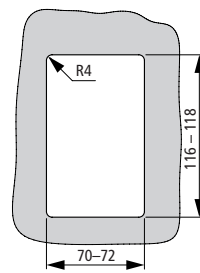
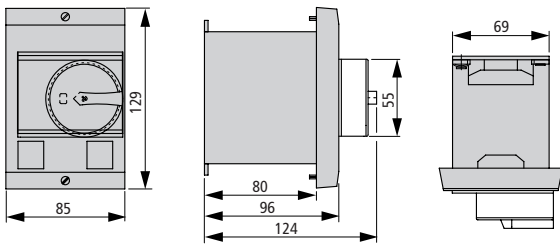

E-PKZ0-G... + SVB-PKZ0-E

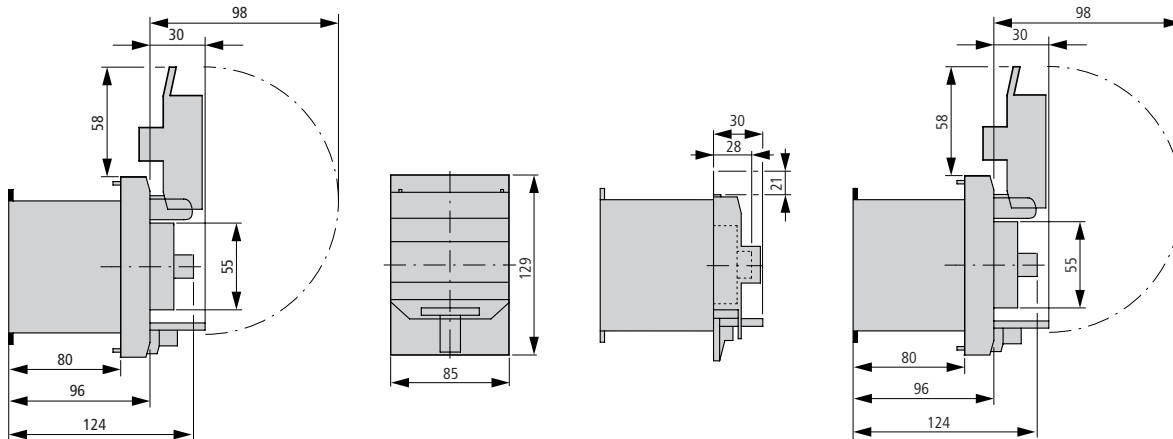

Insulated enclosure for top mounting  
CI23E-125

Mounting plates  
M3-CI23

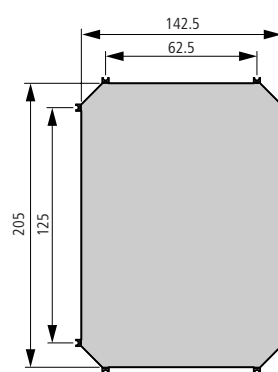
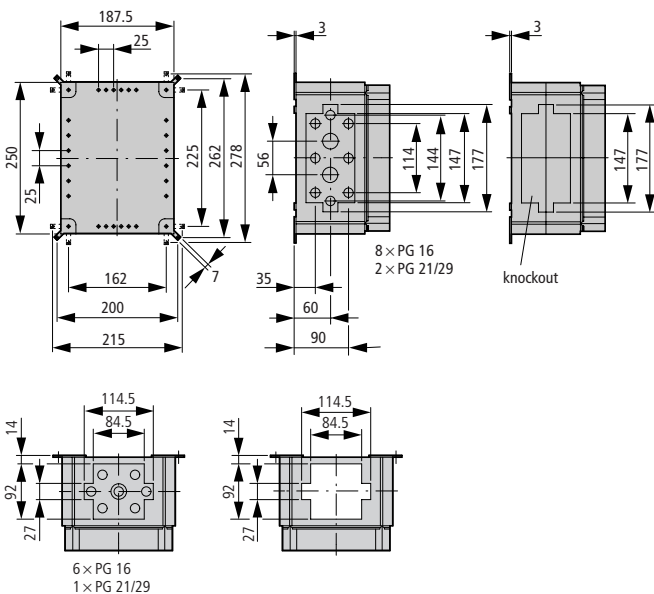

**PKZM01**

Insulated enclosure for top mounting

CI-PKZ01  
CI-PKZ01-G

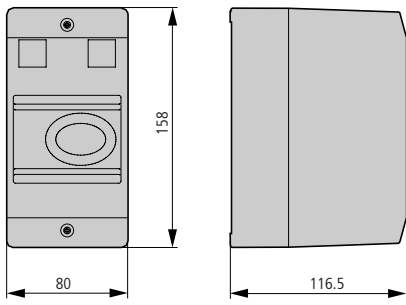

CI-PKZ01-PVT  
CI-PKZ01-PVS

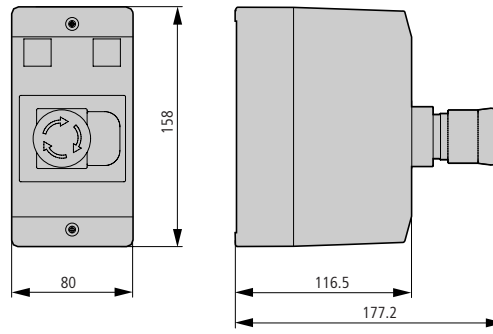

CI-PKZ01-SVB  
CI-PKZ01-SVB-V

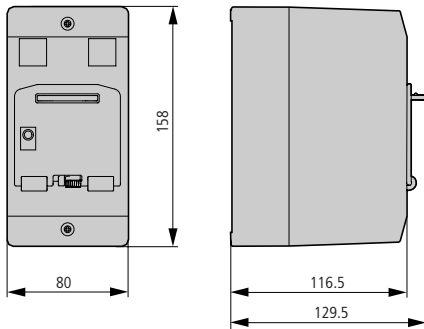

Insulated enclosure for flush mounting

E-PKZ01  
E-PKZ01-G

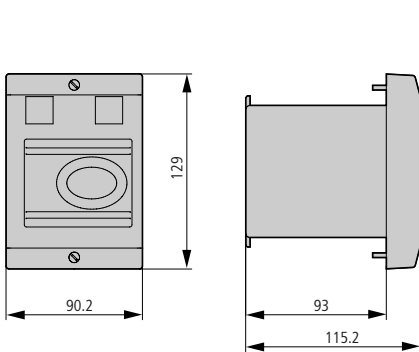

E-PKZ01-PVT  
E-PKZ01-PVS

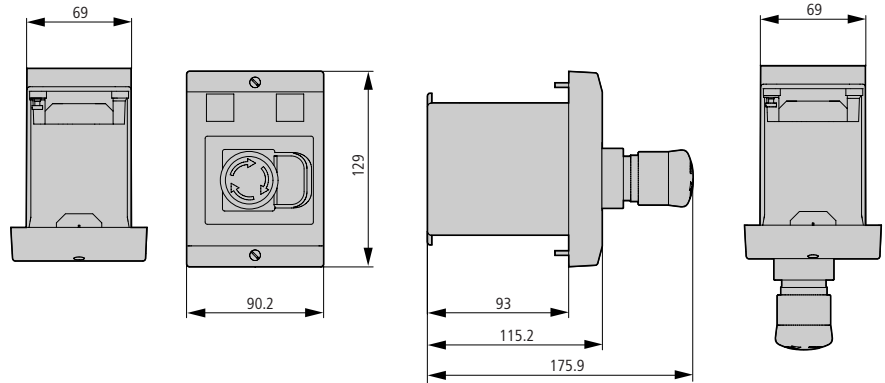

E-PKZ01-SVB  
E-PKZ01-SVB-V

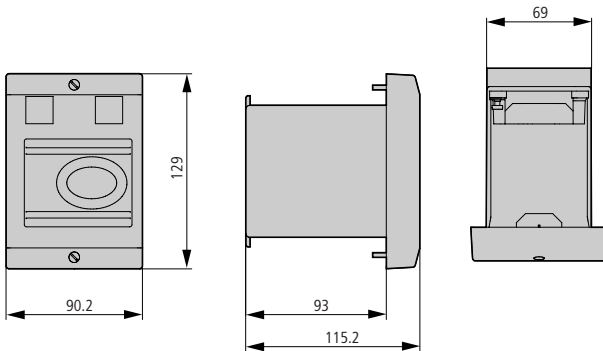

Motor-protective circuit-breakers  
PKZM4-...

Standard auxiliary contacts

NHI...-PKZ...  
NHI...-PKZ0

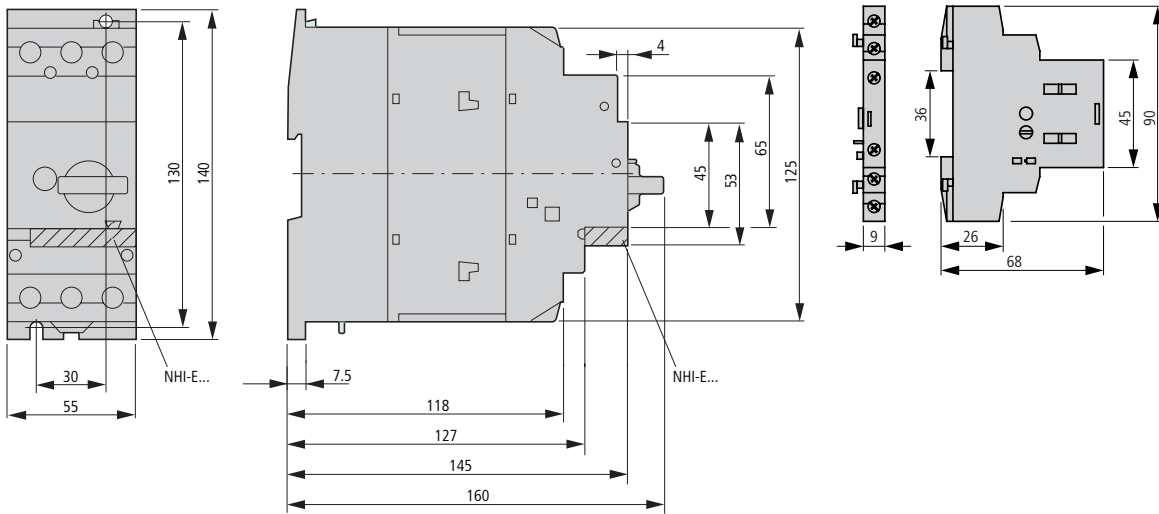

Motor-protective circuit-breakers with lockable cover  
PKZM4-... +AK-PKZ0

Trip-indicating auxiliary contacts

AGM2...-PKZ...  
AGM2...-PKZ0

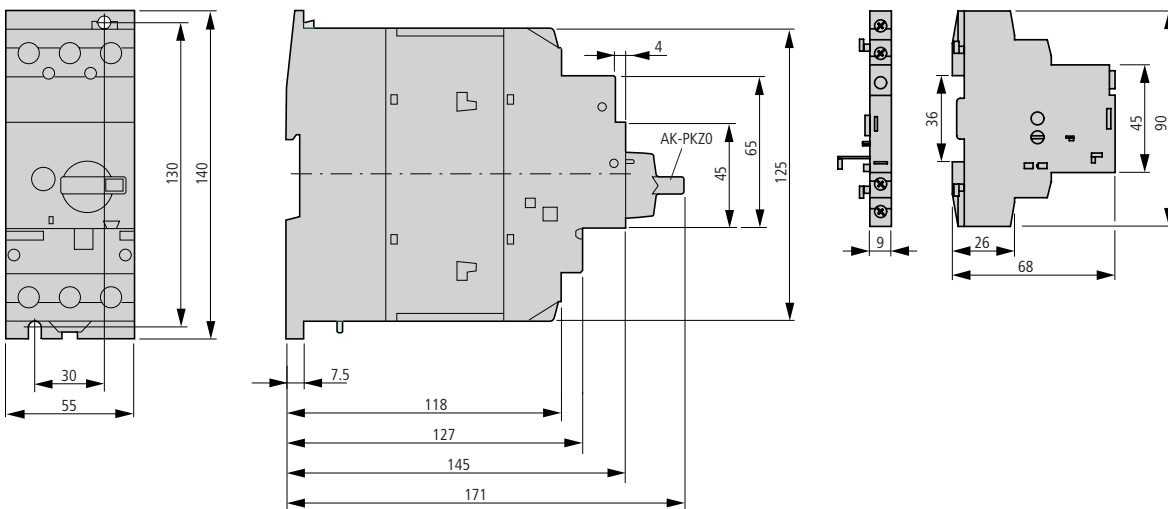

Three-phase commoning links  
B3.0/4-PKZ4

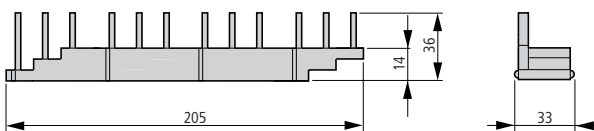

B3.2/4-PKZ4

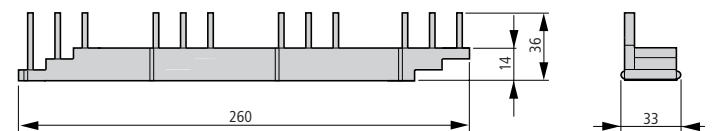

B3.0/3-PKZ4

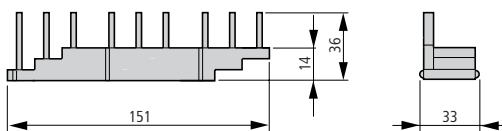

B3.2/2-PKZ4

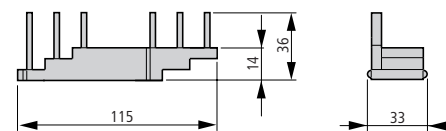

B3.0/2-PKZ4

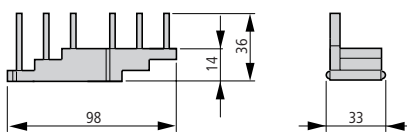

B3.1/3-PKZ4

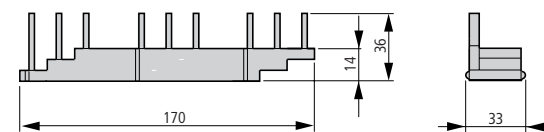

B3.1/4-PKZ4

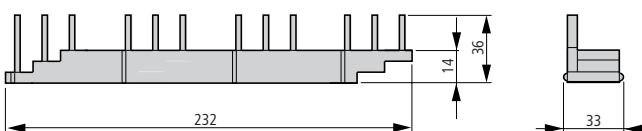

B3.1/2-PKZ4

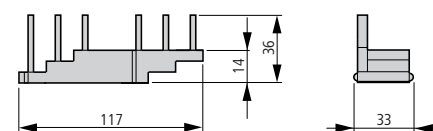

PKZM4

Insulated enclosure for top mounting  
CI-K4-PKZ4-G

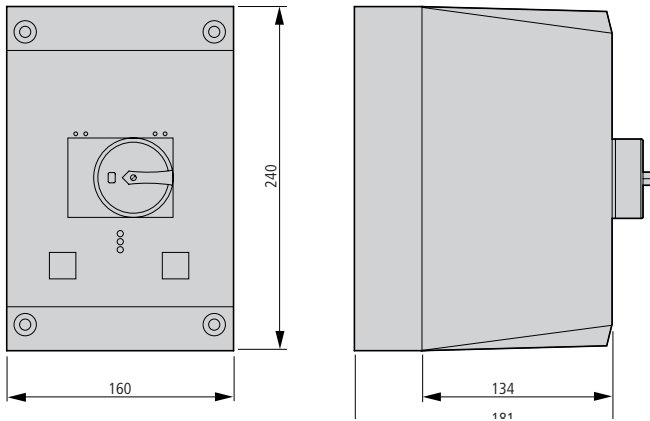

CI-K4-PKZ4-G(R)  
+SVB-PKZ4-CI

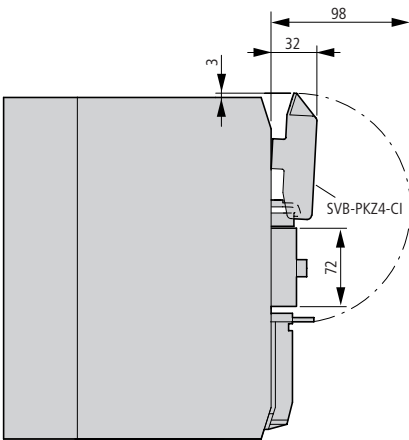

Drilling dimensions  
CI-K4-PKZ4-G(R)

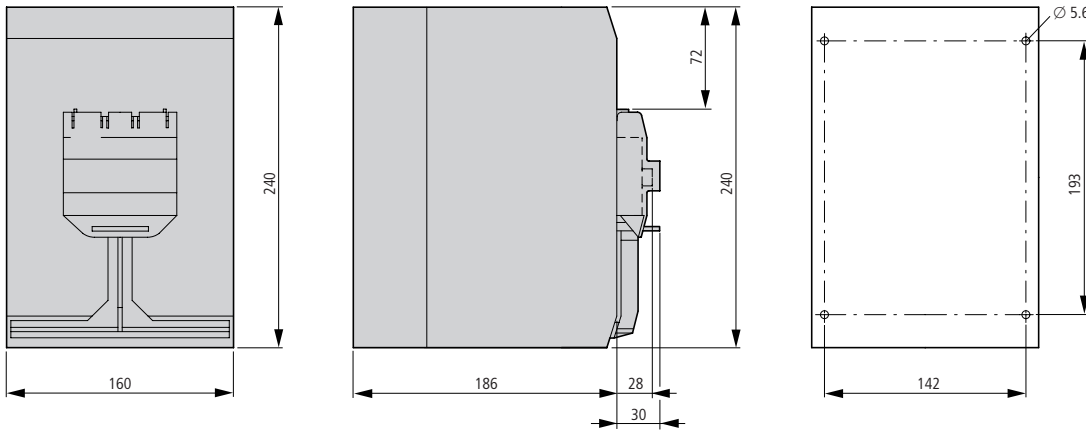



Motor-protective circuit-breakers

<http://catalog.moeller.net>

Moeller HPL0211-2007/2008

PKZ2

Motor-protective circuit-breaker and trip block  
PKZ2/ZM... + ZMR...-PKZ2

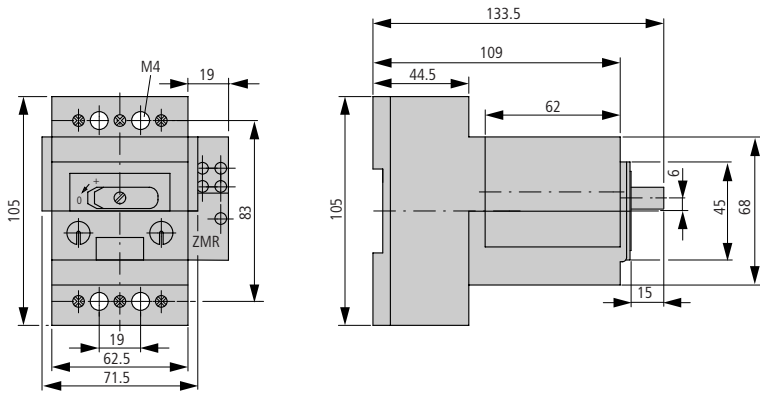

Trip-indicating auxiliary contacts  
AGM2-11-PKZ2

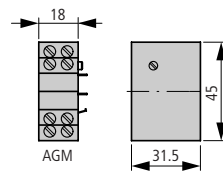

Protective switch  
PKZ24

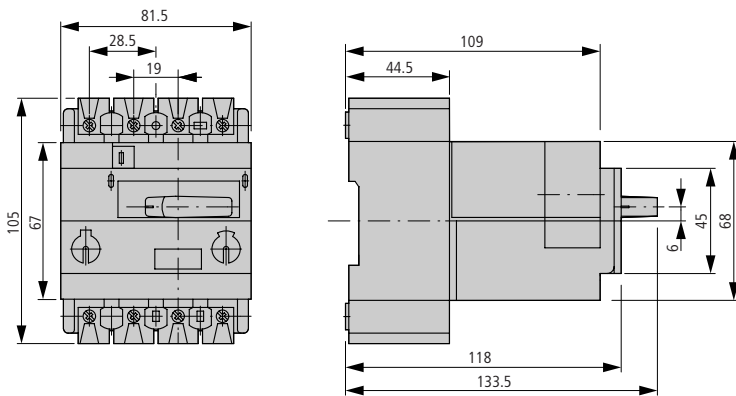

Standard auxiliary contacts  
NHI...-PKZ2

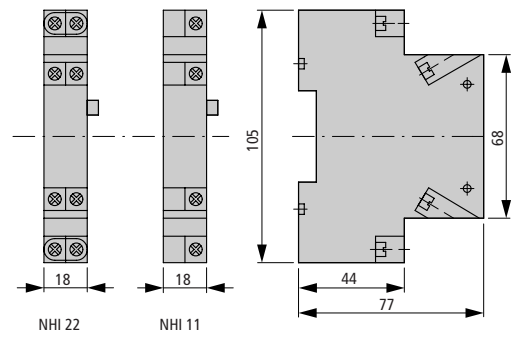

Remote operator

RE-PKZ2(...)  
RS-PKZ2(...)

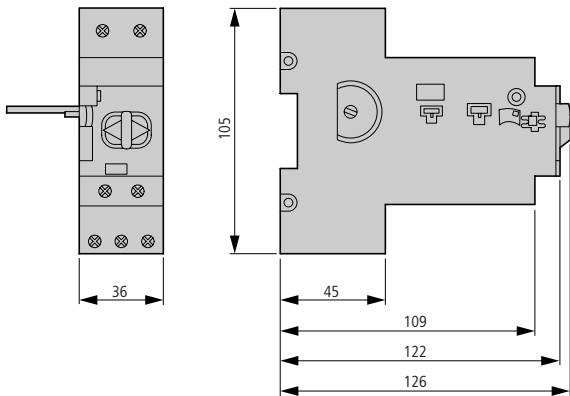

Shunt releases  
Undervoltage releases  
U-PKZ2...  
A-PKZ2...

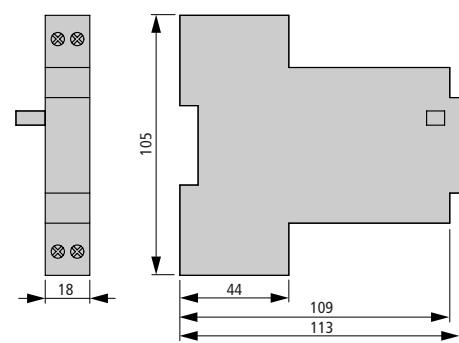

PKZ2 motor-protective circuit-breaker



### PKZ2

High-capacity compact starters

PKZ2/ZM-.../S  
PKZ2/ZM-.../S

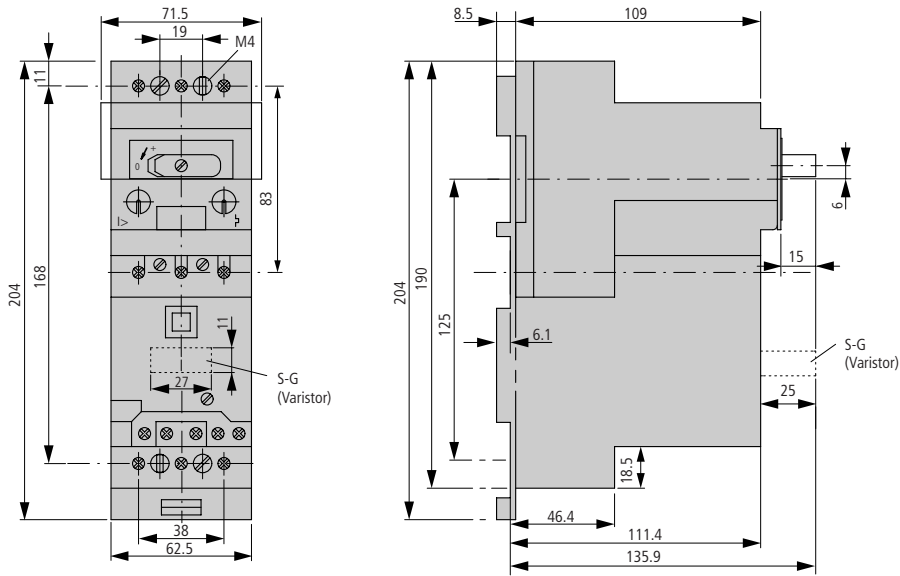

Standard auxiliary contacts for (high-capacity) compact starter

NHI...-PKZ2

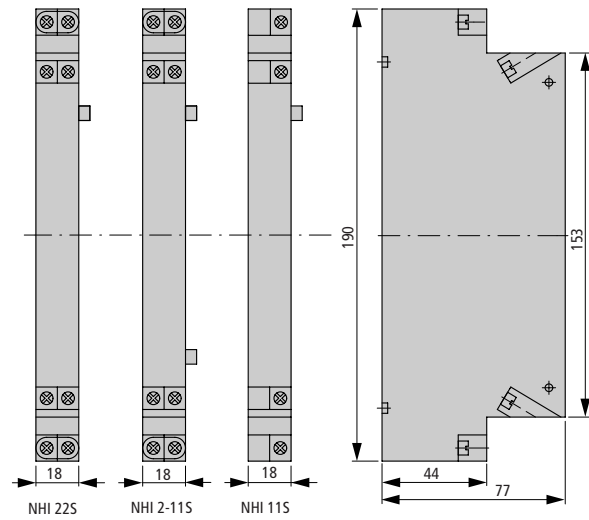

Contact modules

High-capacity contact module

Current limiters

SE1A/11-PKZ2(...)

S-PKZ2(...)

CL-PKZ2

Bases for separate mounting

Auxiliary contact, separate mounting

EZ-PKZ2

HI11-S/EZ-PKZ2

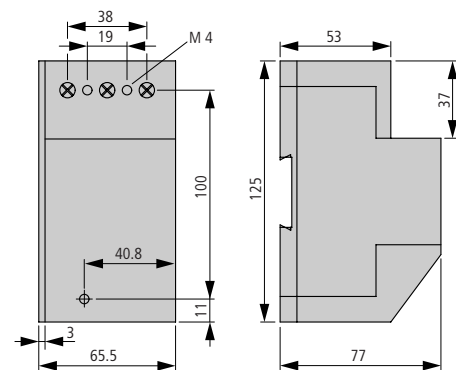
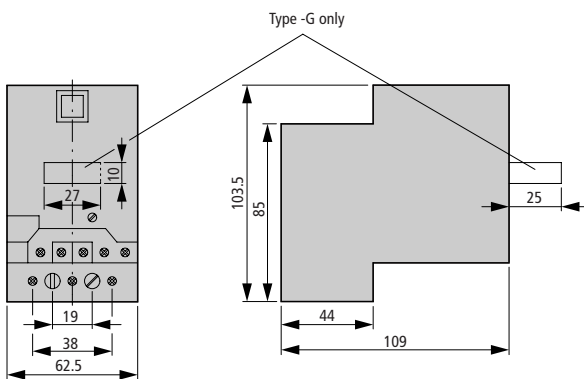

Insulated enclosures for surface mounting

CI19EA-PKZ2

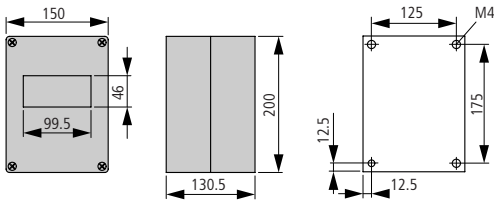

CI19EB-PKZ2

CI19ED-PKZ2

Drilling dimensions

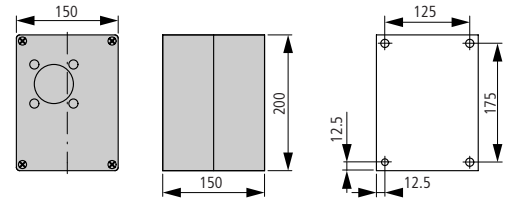

CI23EA-PKZ2

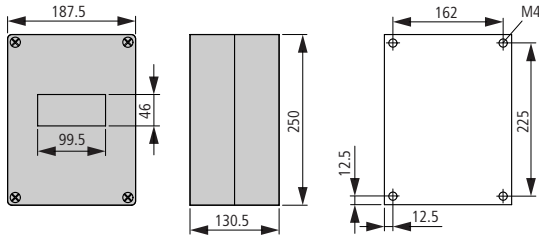

CI23EB-PKZ2

Drilling dimensions

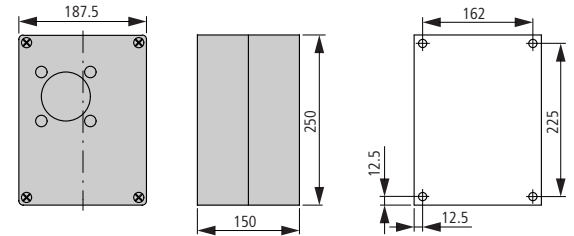

Insulated enclosure for flush mounting

E-PKZ2  
E54-PKZ2

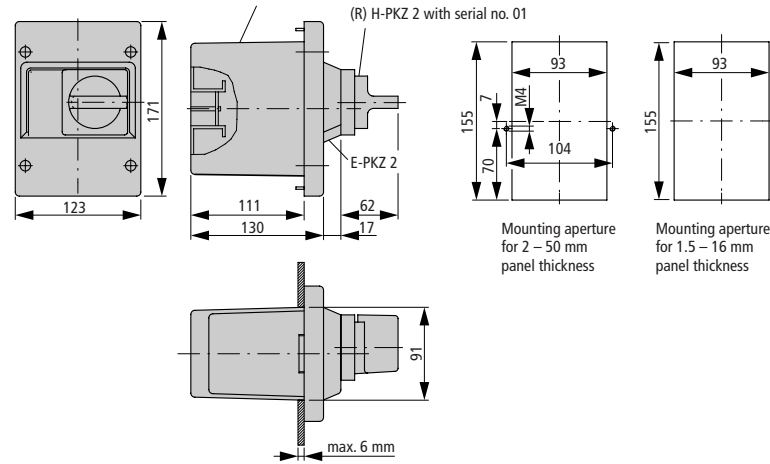

Door coupling handles

PKZ2-X...

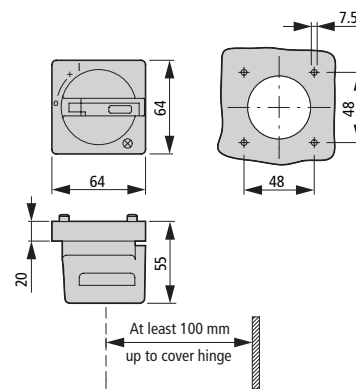

Three-phase commoning link

B3.1/3-PKZ2

B3.1/2-PKZ2

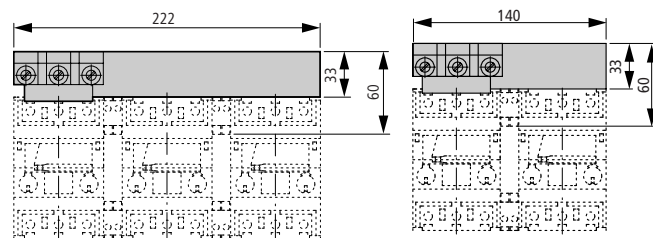

Incoming terminal

BK50/3-PKZ2

Shroud for unused terminals

H-B3-PKZ2

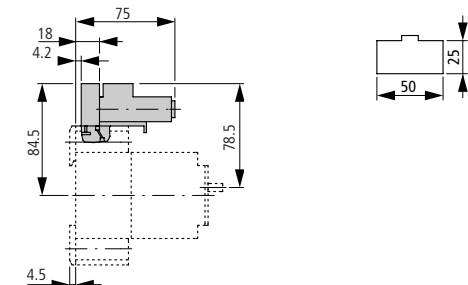

Mechanical interlock with (high-capacity) contact module

MV-PKZ2

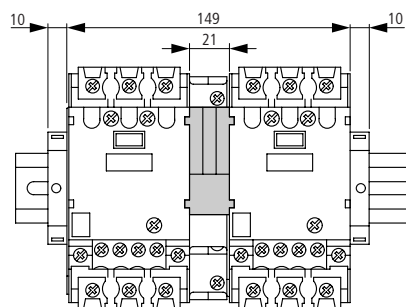

Neutral terminal for (high-capacity) contact module

N-PKZ2

